

AIRMAN

INSTRUCTION MANUAL

SCREW COMPRESSOR

PDS100S-6B4
PDS130S-6B4
PDS185S-6B4

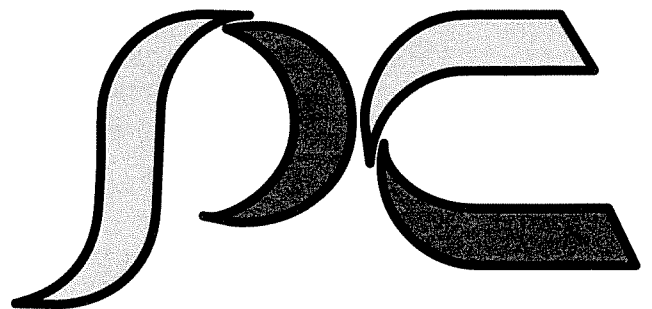

HOKUETSU INDUSTRIES CO., LTD.

Preface

- ◆ This manual explains and illustrates proper handling of the unit, method of daily inspection and maintenance to enhance the performance of AIRMAN's compressors.
- ◆ In order to use a machine safely, people with sufficient knowledge and sufficient technology need to deal with it.
- ◆ Before operating the unit, read the manual carefully, fully understand its operation and maintenance requirement. Maintain "SAFETY OPERATION AND PROPER MAINTENANCE OF THE UNIT".

Be sure to follow safety warnings and cautions given in the manual. Unsafe operation could cause serious injury or death.

- ◆ For details of handling, maintenance and safety of the engine, see the Engine Operation Manual.
- ◆ Keep the manual available at all times for the operator or safety supervisor.
- ◆ If the manual is lost or damaged, place an order with your dealer for another copy.
- ◆ Be sure that the manual is included with the unit when it is handed over to another user.
- ◆ There may be some inconsistency in detail between the manual and the actual machine due to improvements of the machine. Ask your dealer if you have any questions or problems.
- ◆ If you have any questions about the unit, please inform us the model and serial number. A plate stamped with the model and serial number is attached to side of the unit.
- ◆ Each illustrated figure (Fig.) has a number of 7 digits (for instance, A990054) at the right bottom. This number is not a part number, but it is used only for our reference number.

PORTABLE COMPRESSOR	
MODEL	<input type="text"/>
SER. NO.	<input type="text"/>
NORMAL OPERATING PRESSURE	<input type="text"/> MPa
NET DRY MASS	<input type="text"/> kg
AIRMAN MADE IN JAPAN HOKUETSU INDUSTRIES CO., LTD. 22-2, NISHI-SHINJUKU 1-CHOME, SHINJUKU-KU TOKYO JAPAN	

A990054

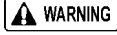
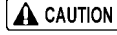

Table of Contents

1. Safety	1-1
1.1 Caution before Operation	1-2
1.2 Caution during Operation	1-6
1.3 Caution during Inspection and Maintenance	1-8
1.4 Safety Warning Labels	1-12
2. Operation	2-1
2.1 Unit Appearance and Part Names	2-1
2.2 Internal Components and Part Names	2-2
2.3 Instrument Panel	2-3
2.4 Compressed Air Service Valve	2-5
2.5 Door	2-5
2.6 Check before Starting Unit	2-5
2.7 Unit Operation	2-12
2.8 Stopping Procedures	2-15
3. Transportation and Towing the Unit	3-1
3.1 Transportation	3-1
3.2 Towing the Unit	3-2
4. Installation	4-1
4.1 Location and Installation	4-1
5. Periodic Inspection/Maintenance	5-1
5.1 Important Items as Periodic Inspection and Maintenance or after Maintenance	5-1
5.2 Daily Inspection and Operation Log	5-2
5.3 Periodic Inspection List	5-3
5.4 Periodic Replacement of Parts	5-5
5.5 Items and Places of Inspection	5-6
5.6 Maintenance Items	5-7
6. Maintenance/Adjustment	6-1
6.1 Adjustment of Regulator	6-1
6.2 Maintenance of Battery	6-2
6.3 Troubleshooting	6-4
7. Storage of the Unit	7-1
7.1 Preparation for Long-term Storage	7-1
8. Specifications	8-1
8.1 Compressor Specifications	8-1
9. Wiring Diagram	9-1
10. Piping Diagram	10-1

1. Safety

This manual explains and illustrates general requirements for safety.

Read all safety requirements carefully and fully understand the contents before starting the machine.

For your better recognition, according to the degree of potential danger, safety messages are classified into three hierarchical categories, namely, , , and  with a caution symbol  - attached to each message.

When one of these messages is shown, please take preventive measures and carry out “SAFETY OPERATION AND PROPER MAINTENANCE OF THE UNIT”.



DANGER indicates an imminently hazardous situation which, if not avoided, will result in death or serious injury. This signal word is to be limited to the most extreme situations.



WARNING indicates a potentially hazardous situation which, if not avoided, could result in death or serious injury.



CAUTION indicates a potentially hazardous situation which, if not avoided, may result in minor or moderate injury. It may also be used to alert against unsafe practices.



IMPORTANT indicates important caution messages for the performance or durability of the unit.

Follow warnings mentioned in this manual. This manual does not describe all safety items. We, therefore, advise you to pay special attention to all items (even though they may not be described in the manual) for your safety.

1. Safety

1.1 Caution before Operation



Compressed air is prohibited to be used for human respiration

- Compressed air by this unit contains poisonous materials. Absorption of the compressed air can cause serious injury. Never provide this compressed air for human respiration.
- This unit is not designed to be used for working chambers pressurized by compressed air such as respiratory air provided to persons working inside wells and tunnels such as pneumatic engineering method and pneumatic caisson method. Should this unit stop operation due to trouble, it can cause death and serious injury to the working persons. Refrain from using the compressed air for such pneumatic engineering method or pneumatic caisson method.

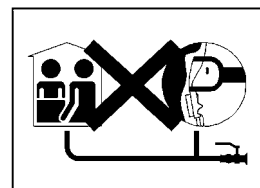

TR0201-1

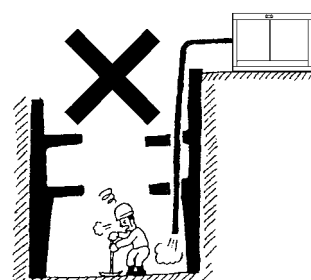

A080001



Ventilation

- Exhaust gas from the engine is poisonous, and could cause serious injury or death when inhaled. Avoid using the machine in an insufficiently ventilated building or tunnel.

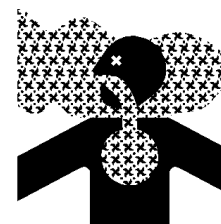

PC002



Follow all safety instructions

- Read each instruction plate which is displayed in the manual or on the unit carefully, understand its content and follow the directions.
- Keep the Safety Warning labels clean. If they are damaged or missing, apply new ones.
- Do not modify the machine without prior approval. Safety of the unit may be compromised, functions may be deteriorated, or machine life may be shortened.
- Never use the unit for the purpose of compression of gases other than air, or as a vacuum pump. Serious accidents may occur.

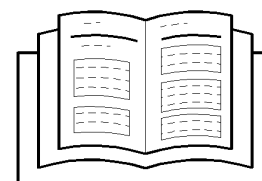

TR0086



Maintain both physical and mental health

- Do not operate the machine you are tired, intoxicated or under the influence of drugs. Operation under these circumstances may cause unexpected injury or accident. Maintain your physical and mental health and be cautious in handling the machine.

1. Safety

WARNING

Safety outfit

- When handling the machine, do not wear;
- loose clothes
- clothes with unbuttoned sleeves
- hanging tie or scarf
- accessories such as dangling jewelry

Such outfit could be caught in the machine or dragged in the rotating portion of the machine which could cause a serious injury.



TR0084

WARNING

Transportation

- When loading and unloading unit, be sure to use the lifting bail provided on the center of the unit top.
- Never get under the unit which is suspended, it is very dangerous.
- When unit is transferred or moved from a working site, be sure to place it on truck bed, and tie it down firmly. Also be sure to put a set of chocks to fix its wheels firmly in position.
- Never lift unit which is still in operation. It could cause critical damage to each component or lead to serious accident.

WARNING

Installation

- The machine should be parked horizontally on a level place.
- In case the machine has to be parked on a slope, place it across grade so that the machine does not tend to roll downhill.
- Grade on a slope shall be within 15 degrees
- Be sure to put one set of chocks " 1 " to the wheels.

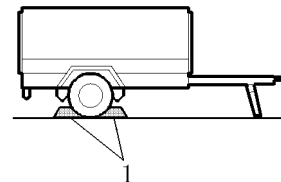

A000054

WARNING

Cautions of hose attachment and removal

- Piping or the hose from this machine service valve should use what can be borne enough for the discharge pressure of this machine.
- Please connect piping or a hose to this machine service valve firmly before operation and during operation. If the connection part is loosening, there is a possibility of piping or a hose separating and getting seriously injured.
- Please remove after closing a service valve and extracting pressure remained, in case piping or a hose is removed. If pressure remained should remain, a near thing blows away or there is a possibility of a hose whipping, causing a phenomenon and getting seriously injured.
- In order to use it safely, please read the handling of the work tools often used.

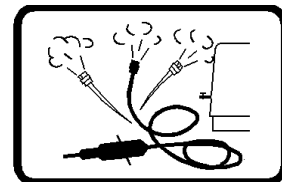

TR0088

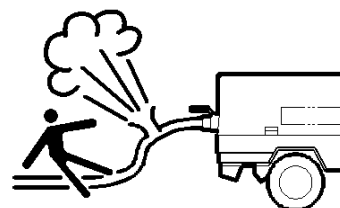

TR0303A

1. Safety

WARNING

Handling battery

- Keep flames away from battery.
- Battery generates hydrogen gas and may explode.
- Therefore, recharging should be done at a well-ventilated place.
- Do not allow sparks or flame near the battery.
- Do not check the battery by short-circuiting the positive and negative terminals.
- Never operate the machine nor charge the batteries with the battery liquid level being kept lower than the "LOWER" level. Continuing operation at this lower level will cause deterioration of such parts as pole plates etc., and also it may cause explosion as well as reduction of battery life. Add distilled water so that the liquid level may reach the middle level between the "UPPER" and "LOWER" level without any delay.
- Do not charge a frozen battery. Otherwise it may explode. If the battery is frozen, warm it up until the battery temperature becomes 61°F to 86°F (16°C to 30°C).
- Battery electrolyte is dilute sulfuric acid. In case of mishandling, it could cause skin burning.
- When you deal with a battery, please be sure to wear protection implements, such as protection glasses and a glove.
- When such battery electrolyte contacts your clothes or skin, wash it away with large amount of water immediately.
- If the battery electrolyte gets into your eyes, wash it away immediately with plenty of water and seek medical attention.
- Dispose of battery, observing local regulations.



D004

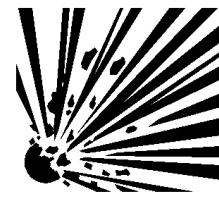

W010



TR0093

CAUTION

Check before starting the unit

- Be sure to check the unit before operation. When any abnormality is found, be sure to repair it before restarting the unit.
- Be sure to make daily checks before operation. If the unit is operated without prior check and without noticing any abnormality, operation could cause damage of components or may even cause fire.

1. Safety

CAUTION

Protection equipments

- Please wear protection implements, such as a helmet, protection glasses, earplugs, safety shoes, a glove, and a protection-against-dust mask, according to the contents of work for safety.



TR0085

CAUTION

Safety fittings

- Have first-aid kits and fire-extinguishers near the unit ready for emergency situations.
- It is advisable to have a list of phone numbers of doctors, ambulance and the fire department available in case of emergency.



TR0096

CAUTION

Safety around the machine

- Unnecessary equipment and tools, cables, hoods, covers which are a hindrance to the job, have to be removed.

1. Safety

1.2 Caution during Operation



Do not replenish compressor oil during operation

- Do not, under any circumstance, open the oil filler cap of separator receiver tank while running or immediately after stopping operation. It is very dangerous and cause serious injury.
- Relieve all pressure before performing any maintenance.

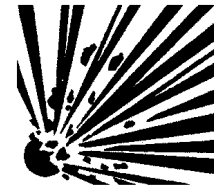

W010



Draining during operation prohibited

- Do not, under any circumstance, open the items listed below during operation:
- Separator receiver tank drain valve
- Coolant drain valve and plug
- Engine oil drain plug
- Oil cooler drain plug



PK0028



Beware of cooling fan

- Never put your hand near the engine cooling fan during operation.

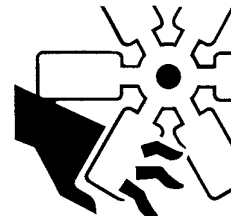

W009



Hands off from rotating parts and belts

- Keep hands off from the rotating portion or belts while running.

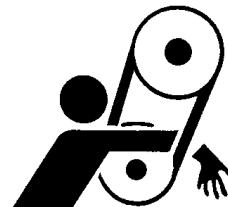

TR0304

1. Safety



WARNING

Never direct the compressed air to people and foods

- Never blow compressed air directly at people. Scattered dust, or foreign objects in the compressed air may cause serious injuries.
- Blowing compressed air on food is prohibited.

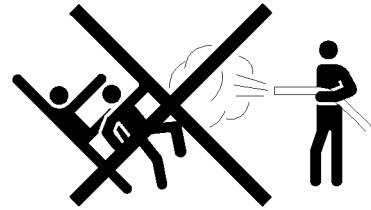

TR0092



CAUTION

Do not remove radiator cap during operation

- Do not, under any circumstance, open the radiator cap while running or immediately after stopping operation. Otherwise high temperature steam releases out and this could cause scalding.



H990432



CAUTION

Do not touch hot parts

- Never work near hot portions of the machine while it is running.
- Such parts as engine, exhaust manifold, exhaust pipe, muffler, radiator, oil cooler, compressor, piping, separator receiver tank, and discharging pipe are especially hot, so never touch those parts, because it could cause serious burns.
- Compressor oil, coolant water, and engine oil are also very hot and dangerous to touch.
- Avoid checking or refilling them while the unit is running.



H990432



CAUTION

Operation with compressed air supply port opened is prohibited

- Do not operate the machine with service valves and relief valve open unless air hoses and/or pipes are connected.
- When the machine has to be unavoidably temporarily operated with its port open, be sure to mount a silencer to reduce noise and wear protective materials such as earplugs to prevent damage to hearing. For testing service only.

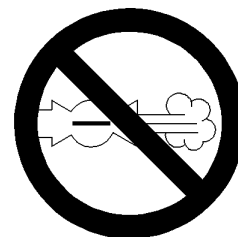

D003

1. Safety

CAUTION

Fire prevention

- Do not, under any circumstance, bring lit cigarettes or matches near oils as engine oil and compressor oil, etc. They are extremely flammable and dangerous.
- Refilling oils should be done in an outdoor well-ventilated place.
- Refuel after stopping the engine, and never leave the fuel nearby the machine. Do not spill. Clean environmental spills.
- Such parts as muffler and exhaust pipe can be extremely hot. Remove twigs, dried leaves, dried grass and waste paper, etc. from the exhaust outlet of the muffler.
- Keep a fire extinguisher available by the machine in case of a fire.



D004



H990433

1.3 Caution during Inspection and Maintenance

WARNING

Hang a "Now Checking and under Maintenance" tag

- Remove the starter key from the starter switch before starting inspection, and hang up a "Now Checking and under Maintenance" tag where it can be easily seen. The checker must keep the key during checking and maintenance.
- Remove the negative (-) side cable from the battery.

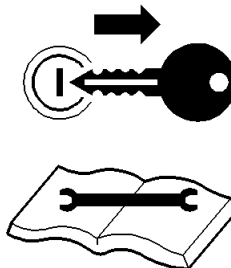

SY001

WARNING

Refilling of compressor oil

- When you refill the separator receiver tank with compressor oil, stop the engine, and make sure that the pressure gauge indicates 0 psi (0 bar) and there is no residual pressure in it, and then gradually loosen the oil filler cap for refilling oil.
- Note residual pressure in the separator receiver tank could force both extremely hot compressed air and oil to jet out and you may be scalded or seriously injured.

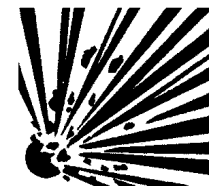

W010

1. Safety

WARNING

Draining separator receiver tank

- After stopping the engine, confirm that the pressure gauge indicates 0 psi (0 bar) and there is no residual pressure in it, then open the drain valve gradually to drain the compressor oil.
- Note residual pressure in the separator receiver tank could force both extremely hot compressed air and oil to jet out and you may be scalded or seriously injured.



H990432

WARNING

Be careful of high-pressurized air blowout

- After stopping the engine, make sure that pressure gauge indicates 0 psi (0 bar). Even when the gauge shows 0 psi (0 bar), open a service valve and further do not fail to make sure that there is no residual pressure in the air piping. Then begin repair and maintenance.
- Residual air under pressure can cause severe injury.

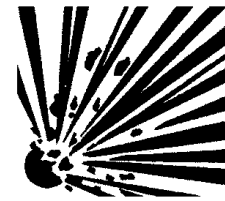

W010

WARNING

Adjusting tension of fan belt

- Be sure to stop the engine and remove the starter key whenever the tension of the fan belt is to be adjusted.
- Remove the negative (-) side cable from the battery.
- If the machine is running, it might catch the operator's hand into the fan belts, and this could cause a serious injury.

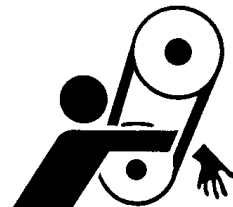

TR0304

WARNING

Hands off from cooling fan

- Be sure to stop the engine and remove the starter key whenever check or maintenance work is carried out near the cooling fan.
- If the cooling fan is rotating, it may catch the operator or part of his body into the fan, and it could cause a serious injury.

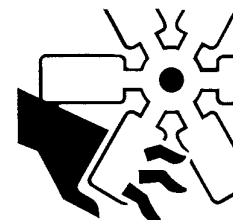

W009

1. Safety

WARNING

Cleaning by air-blow

- When cleaning dust accumulated in such devices as the air-filter, by blowing compressed air, wear safety glasses, etc. to protect your eyes.



M003

CAUTION

Lighting apparatus

- It is recommended to use a lamp with safety guard fitted in low light conditions.
- Any lamps without safety guard are not recommended since they can be broken and they could ignite flammables such as fuel, etc.

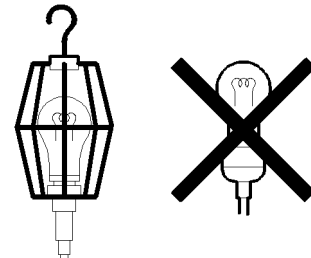

TR0206

CAUTION

Taking off the radiator cap

- Be sure to stop the machine and allow time to cool. Then loosen the radiator cap one notch. After the coolant water is sufficiently cooled and the inner pressure is released, take the cap off.
If this procedure is neglected, the inner pressure can blow off the cap. Steam jetting out of the radiator could result in scalding. Follow this procedure under all circumstances.



H990432

CAUTION

Opening coolant water drain valve cap

- Be sure to stop the engine, and let the coolant water sufficiently cool down before draining it.
- If the drain valve is opened before the coolant water is cooled enough, hot water could jet out, and it could cause scalding.



H990432

1. Safety

CAUTION

Refilling or draining of engine oil

- After stopping the engine, wait for 10 to 20 minutes until the engine oil cools off. Then check the level of the engine oil, or refill or drain the oil.
- Engine oil is very hot and highly pressurized during or just after the operation. Hot oil could blow out of the tank and can cause scalding.



H990432

CAUTION

Fire warning

- Be sure to perform the periodical check of compressor oil and oil separator.
- Neglecting checks could cause overheat of the oil, resulting in a fire.



H990433

CAUTION

Disposal of waste liquid, etc.

- Waste liquid from the machine contains harmful material. Do not discharge it onto the ground or into the river, lake or sea. Such material will contaminate the environment.
- Be sure to use a container to hold the waste liquid from the machine.
- Be sure to follow the designated regulations when disposing of oil, fuel, coolant (antifreeze), filter, battery or other harmful materials.

1.Safety

1.4 Safety Warning Labels

Following labels are attached to the machine.

Keep them clean all the time. If they are damaged or peeled off, immediately place an order with your nearest dealer for replacement, with the number indicated on the lower right corner of the label. Adhere a new one to the original place.

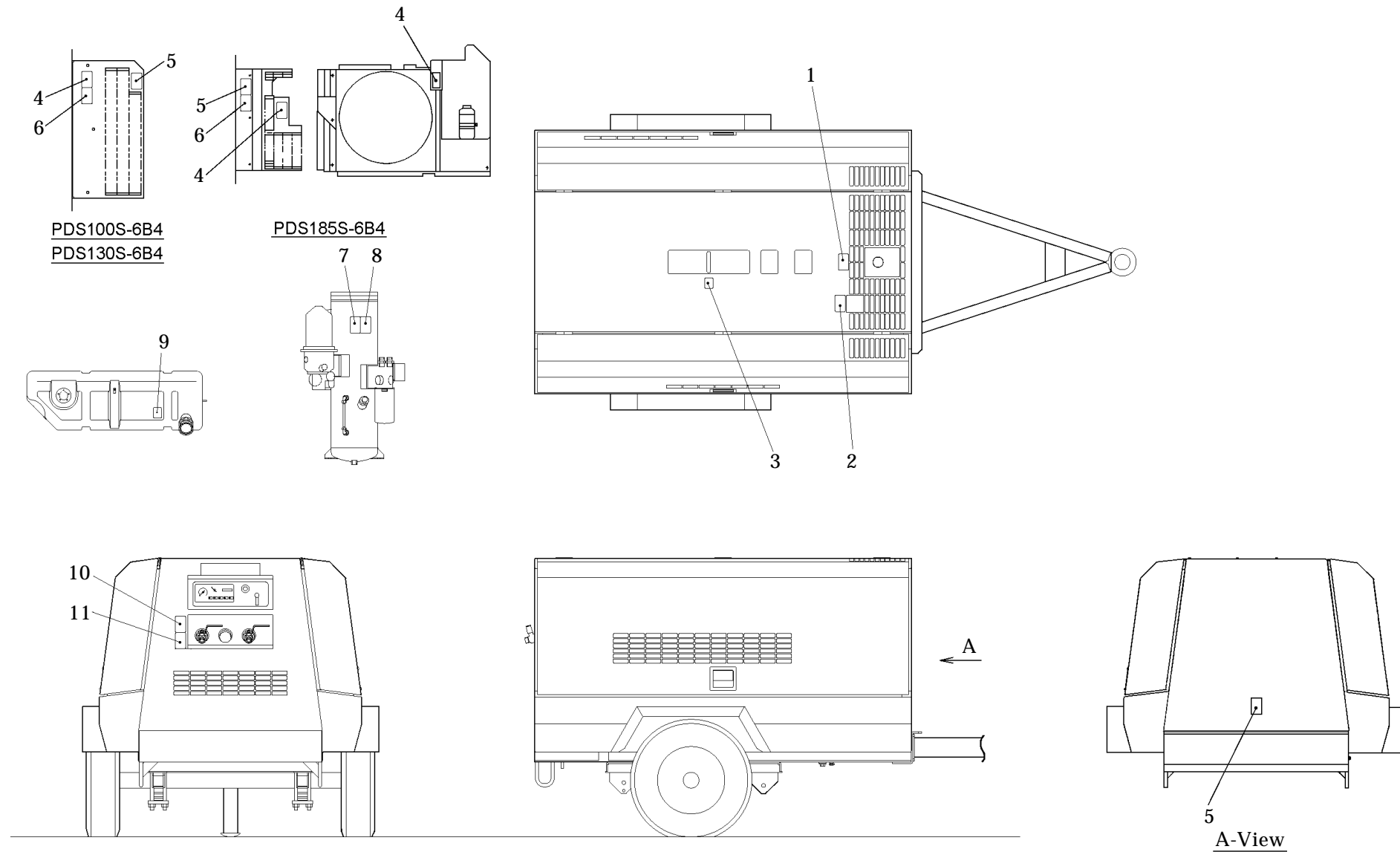

1. Caution, exhaust gases
(39176 73300)

2. Caution, radiator cap
(hot water)
(39176 69600)

3. Lifting bail
(39176 69300)

4. Caution, cooling fan
(39176 73500)

5. Caution, high temp.
(39176 69500)

6. Caution, fan belt
(39176 73800)

7. Caution, Fire
(39176 69700)

8. Caution, residual pressure
(39176 69800)

9. No fire
(39176 35600)

10. Caution, Do not inhale
(39176 73600)

11. Caution, hose whipping
(39176 73400)

A050230

2. Operation

2.1 Unit Appearance and Part Names

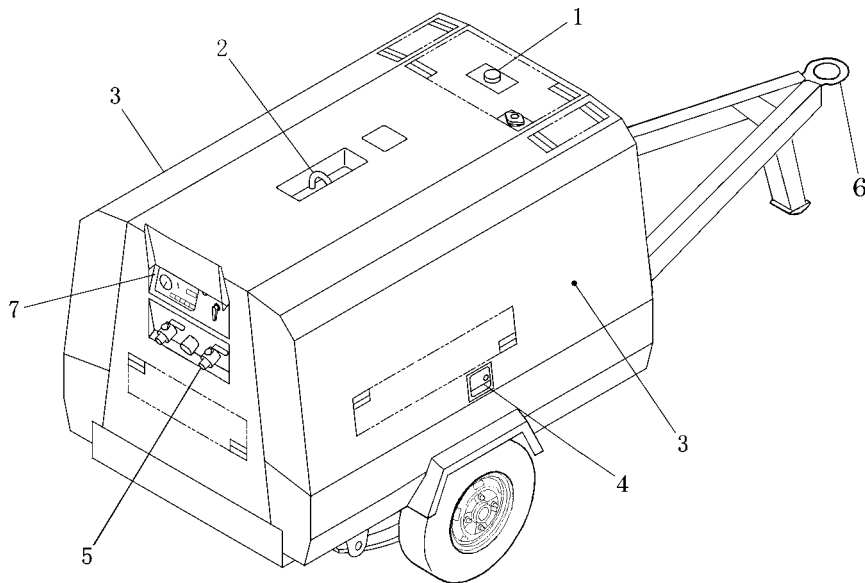

A030132

PDS185S-6B4

- | | |
|-------------------|---------------------|
| 1. Exhaust outlet | 5. Service valve |
| 2. Lifting bail | 6. Drawbar |
| 3. Door | 7. Instrument panel |
| 4. Handle | |

2. Operation

2.2 Internal Components and Part Names

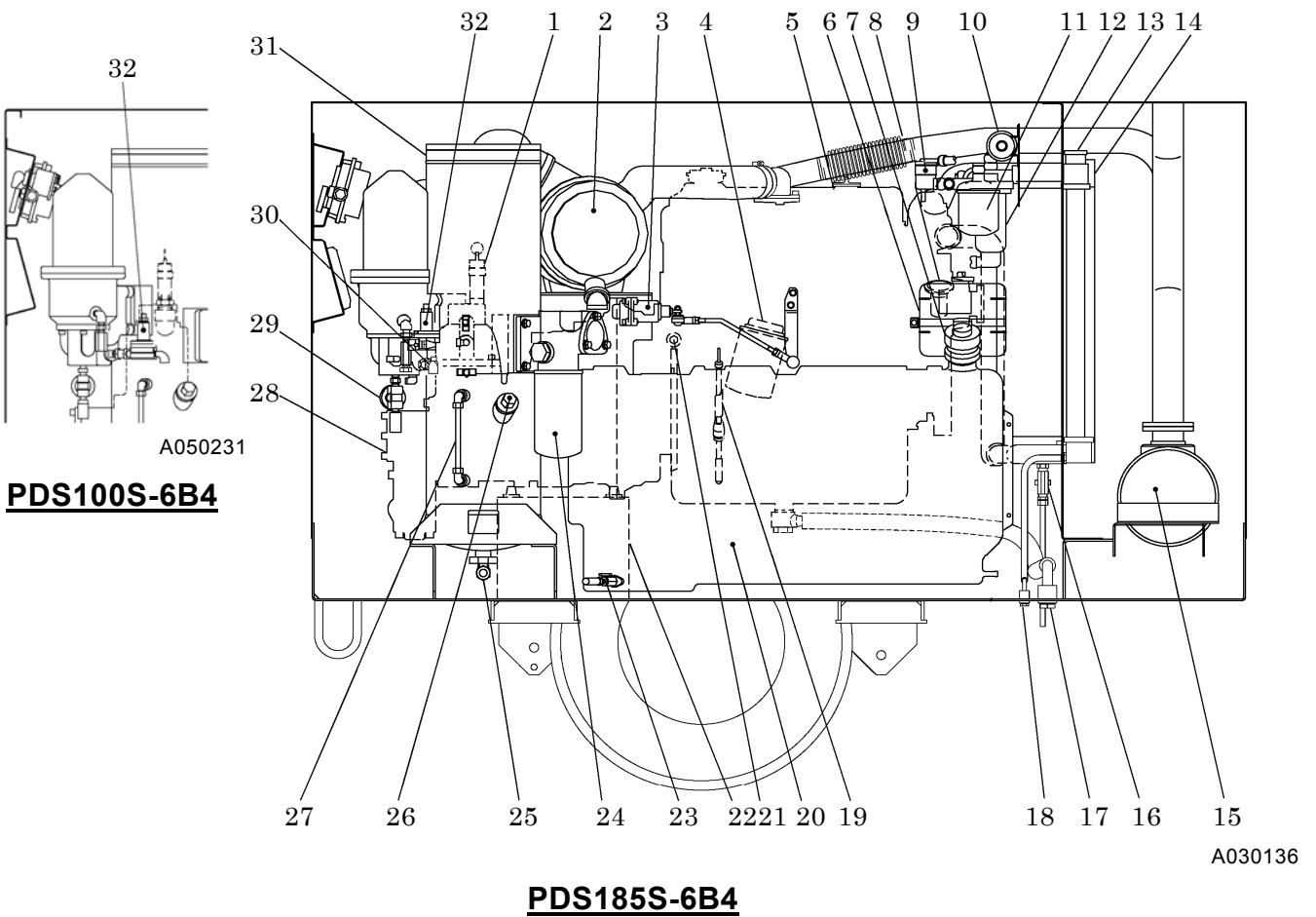

- | | |
|---|---|
| 1. Safety valve | 17. Engine oil drain plug |
| 2. Air filter | 18. Coolant drain plug(Radiator) |
| 3. Speed regulator | 19. Engine oil dipstick |
| 4. Engine oil filter | 20. Fuel tank |
| 5. Engine | 21. Coolant drain valve(Engine) |
| 6. Reserve tank | 22. Battery |
| 7. Fuel filler port | 23. Fuel tank drain valve |
| 8. Engine oil filler | 24. Compressor oil filter |
| 9. Filter for air bleeding electromagnetic pump | 25. Separator receiver tank drain valve |
| 10. Air bleeding electromagnetic pump | 26. Compressor oil filler |
| 11. Fuel filter | 27. Compressor oil level gauge |
| 12. Water sedimentor | 28. Air-end |
| 13. Radiator | 29. Auto- relief valve |
| 14. Oil cooler | 30. Relief valve (PDS130S,PDS185S only) |
| 15. Exhaust muffler | 31. Separator receiver tank |
| 16. Oil cooler drain valve | 32. Pressure regulator |

2. Operation

2.3 Instrument Panel

[PDS100S,130S-6B4]

1. Discharge air pressure gauge
2. Fuel level gauge
3. Elapsed time indicator
4. Starter switch
5. Starting unloader valve

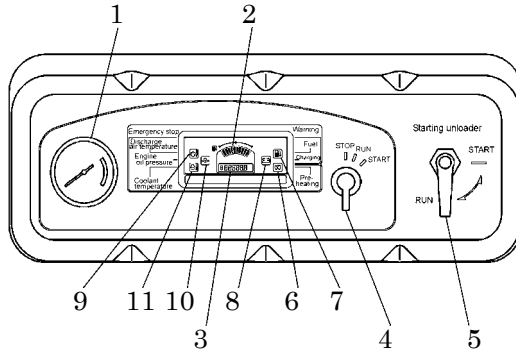

- < Indicator lamp >
- 6. Preheating
- < Warning lamp >
- 7. Fuel residual level
- 8. Charging
- < Emergency stop lamp >
- 9. Discharge air temperature
- 10. Engine oil pressure
- 11. Coolant temperature

A040607E

Indicator lamp

Turn the starter switch to "ON" position. Then the lamp will go on.

Item	Trouble	Measures	Monitor
Preheating	Press starter switch "ON" and the lamp goes on and after preheating is finished, the lamp will be off.	—	

Warning lamp

When some little trouble occurs during operation, the lamp will go on.

When the warning lamp goes on, take appropriate measures to recover the situation swiftly.

Item	Trouble	Measures	Monitor
Fuel residual level	When fuel level of fuel tank becomes lower, the lamp goes on.	Add fuel oil.	
Charging	Lamp goes on when alternator is not charging.	Check wiring. Check alternator.	

Emergency stop lamp

The compressor stops when the emergency stop lamp goes on.

Be sure to follow the measures shown below before starting the unit again.

Item	Trouble	Measures	Monitor
Discharge air temperature	Lamp goes on when the air temperature at the outlet of the air-end reaches the set temperature of 248°F (120°C).	See "Troubleshooting"	
Engine oil pressure	Lamp goes on when engine oil pressure drops. The function pressure is below 0.0392MPa.		
Coolant temperature	Lamp goes on when coolant temperature reaches 230°F (110°C).		

2. Operation

[PDS185S-6B4]

1. Discharge air pressure gauge
2. Fuel gauge
3. Hourmeter
4. Starter switch
5. Starting unloader valve

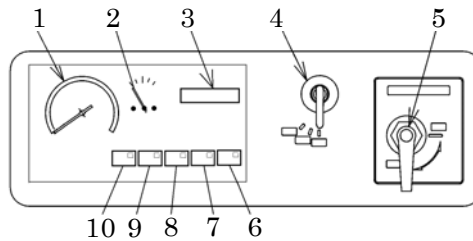

A030155-1

- < Indicator lamp >
- 6. Preheating
- < Warning lamp >
- 7. Charging
- < Emergency stop lamp >
- 8. Discharge air temperature
- 9. Coolant temperature
- 10. Engine oil pressure

Indicator lamp

Turn the starter switch to "ON" position. Then the lamp will go on.

Item	Trouble	Measures	Monitor
Preheating	Press starter switch "ON" and the lamp goes on and after preheating is finished, the lamp will be off.	—	

Warning lamp

When some little trouble occurs during operation, the lamp will go on.

When the warning lamp goes on, take appropriate measures to recover the situation swiftly.

Item	Trouble	Measures	Monitor
Charging	Lamp goes on when alternator is not charging.	Check wiring. Check alternator.	

Emergency stop lamp

The compressor stops when the emergency stop lamp goes on.

Be sure to follow the measures shown below before starting the unit again.

Item	Trouble	Measures	Monitor
Discharge air temperature	Lamp goes on when the air temperature at the outlet of the air-end reaches the set temperature of 248°F (120°C).	See "Troubleshooting"	
Coolant temperature	Lamp goes on when coolant temperature reaches 230°F (110°C).		
Engine oil pressure	Lamp goes on when engine oil pressure drops. The function pressure is below 0.06MPa.		

2. Operation

2.4 Compressed Air Service Valve

2.4.1 Service Valve (20A)

Open the valve by turning the handle clockwise, and close it by turning the handle counterclockwise.

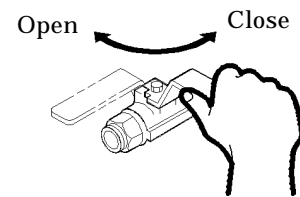

TR0642

2.5 Door

2.5.1 Open/Close the Door

WARNING

- Keep the door closed and locked while running the unit.
- When the door has to be opened, be careful not to touch portions that are rotating or very hot. Careless touch may cause serious injury.



PK0028

- Pull the handle forward to open the door.
- Be sure to close the door tightly so that its latch is firmly caught.

2.6 Check before Starting Unit

CAUTION

Check before starting the unit

- Be sure to check the unit before operation. When any abnormality is found, be sure to repair it before restarting the unit.
- Be sure to make daily checks before operation. If the unit is operated without prior check and without noticing its abnormality, such operation could cause seizure of components or may even cause fire.

2. Operation

2.6.1 Check Items and Locations

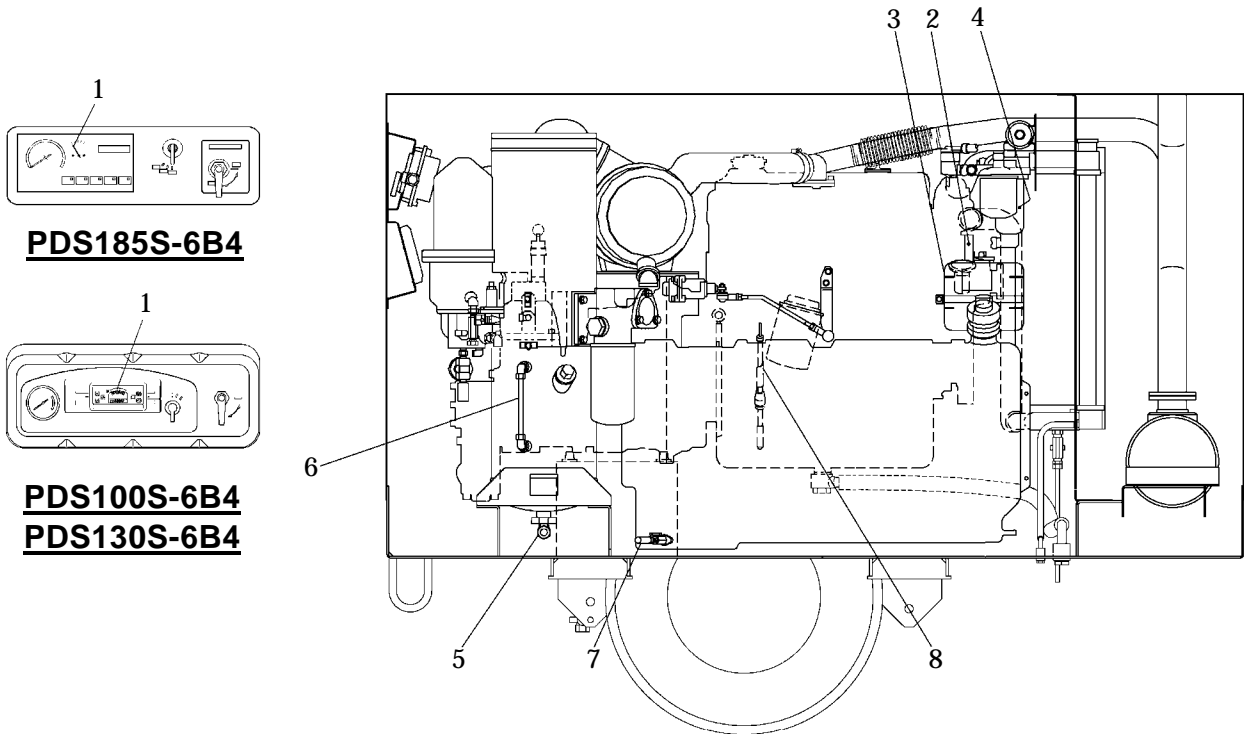

PDS185S-6B4

PDS100S-6B4
PDS130S-6B4

A050233

- | | |
|--|-------------------------------|
| 1. Check fuel | 6. Check compressor oil level |
| 2. Check V-belt tension | 7. Drain fuel tank |
| 3. Check coolant level | 8. Check engine oil level |
| 4. Drain water sedimenter | Check wiring of each part |
| 5. Draining of separator receiver tank | Check piping of each part |

2. Operation

2.6.2 Check Engine Oil Level

- Unit should be on level before checking oil level.
- When you check oil level after you have once started operation, wait 10 to 20 minutes after stopping engine, before checking the oil level.

(Procedure)

Pull out the engine oil dipstick, and wipe it with a clean cloth.

Then, re-insert the dipstick fully and pull it out again. If the dipstick shows the oil level between HIGH and LOW, it is normal.

When the oil level is below its LOW, add engine oil.

(See 5.6.1)

- While checking oil level, check also for contamination. If the oil is found dirty, contaminated or should it be changed according to the periodic inspection list, change the oil.
(See 5.6.1)
- Never fill oil more than HIGH level.

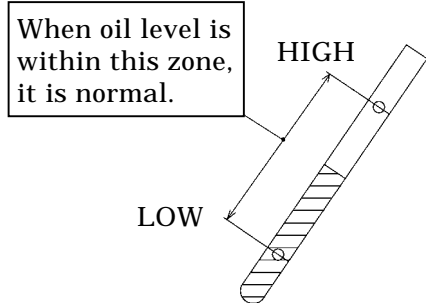

A050232

2.6.3 Check Coolant Level

CAUTION

Taking off the radiator cap

- Be sure to stop the machine and allow time to cool. Then loosen the radiator cap one notch. After the coolant water is sufficiently cooled and the inner pressure is released, take the cap off. If this procedure is neglected, the inner pressure can blow off the cap. Steam jetting out of the radiator could result in causing scalding. Follow this procedure under all circumstances.



H990432

- Check the coolant level in the reserve tank. If it is lower than the limit, open the cap and replenish the coolant. (Level must be kept above LOW mark.)
- If little coolant is left in the reserve tank, replenish the radiator with cooling water. (See 5.6.15)

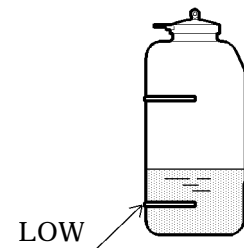

H000036

2. Operation

2.6.4 Check Compressor Oil Level



WARNING

Refilling of compressor oil

- When you refill the separator receiver tank with compressor oil, stop the engine, and make sure that the pressure gauge indicates psi (0 bar) and there is no residual pressure in it, and then gradually loosen the oil filler cap for refilling oil.
- Note residual pressure in the receiver tank could force both extremely hot compressed air and oil to jet out and you may be scalded or seriously injured.

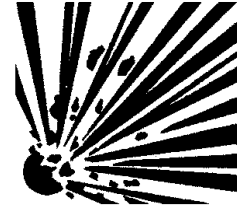

W010

- Place the machine on level ground when checking the oil level.
- Check the oil level of the compressor. Correct oil level is between upper and lower limit of the gauge, when the unit stops. If the gauge shows lower than the middle level, replenish oil. (See 5.6.5)

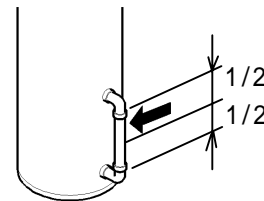

H000037

2.6.5 Draining of Separator Receiver Tank



WARNING

Draining of Separator receiver tank

- After stopping the engine, confirm that the pressure gauge indicates 0 psi (0 bar) and there is no residual pressure in it, then open the drain valve gradually to drain the compressor oil.
- Note residual pressure in the receiver tank could force both extremely hot compressed air and oil to jet out and you may be scalded or seriously injured.



H990432

- Gradually opening the drain valve “ 2 ” fitted under the separator receiver tank “ 1 ” as shown in the fig, drain the condensate.
- Be careful not to fully open the valve. Otherwise, much oil may be lost.
- After draining the oil completely, close the drain valve “ 2 ” firmly.
- Drain the condensate in container “ 4 ”, dispose of the waste oil according to the designated regulations.

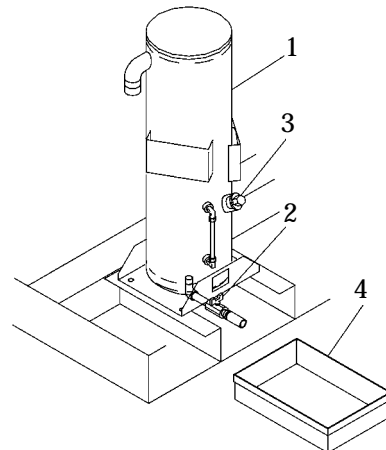

H000038

2. Operation

2.6.6 Check Fuel

CAUTION

Fire prevention

- Do not, under any circumstance, smoke cigarettes or light matches during fueling.
- Fuel is extremely flammable and dangerous. It therefore, could catch fire should it flame or other sources of ignition be brought near fuel. Ensure that the engine is cool. Never fuel a hot machine.
- Refuel only after stopping the engine, and never leave an open fuel can near the machine. Do not spill. It could cause a fire. When it is spilt, wipe it up completely.
- Refilling fuel tank should be done in an outdoor well-ventilated place.



D004

IMPORTANT

———— *Choose appropriate fuel* ————

- Be sure to use diesel fuel oil for diesel engine use.
(Using other oil will cause low power or damage to the engine.)
- As for fuel, use diesel fuel oil (having higher than 45 cetane number).
- Use of diesel fuel oil having lower than 45 cetane number will cause inferior function to engine and, what is worse, it will cause serious accident to the engine.
- Check fuel level gauge before operation. Replenish enough fuel to prevent fuel shortage during operation, if the level is low.
- When refueling, fill a fuel tank up to the base of fuel filler port “ 4 ”. Never overfill fuel because it may cause fuel leakage.
- Be sure to fasten the fuel tank cap firmly after replenishment. If fuel is spilt, wipe it up completely.

2.6.7 Drain Fuel Tank

- Opening the drain valve “ 2 ” fitted under the fuel tank “ 1 ”, drain the condensate from the tank.
- When completely drained, firmly close the drain valve “ 2 ”.
- Drain the condensate in container “ 3 ”, dispose of condensate according to the designated regulations.

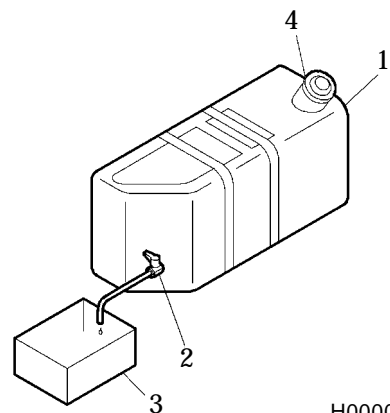

H000039

2. Operation

2.6.8 Drain Fuel filter (PDS100S,130S only)

- Drain condensate when the red float “1” inside the fuel filter rises up to the drainage level “1”.

(Draining procedure)

- ① Turn to the position “Close” the upper lever “3” of the fuel filter.
 - ② Loosen the ring nut “5” to remove the cup “4” .
Carefully take out the cup because it contains fuel.
Be careful not to spill it and soil the interior of the machine.
 - ③ After draining the accumulated water, wash the cup “4” ,and fit it back.
 - ④ Turn the valve “3” to “OPEN” position to refill the fuel in, relieve the air.(See 2.7.3)
- Drain the condensate in container, and then dispose of condensate according to the designated regulations.

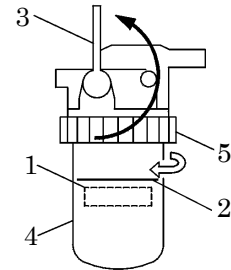

H000040

2.6.9 Drain Water Sedimenter (PDS185S only)

- Check if the red float “1” in the water sedimenter rises up to the water drain level “2” , then drain water if it is near the drain level.

(Draining procedure)

- ① Loosen the drain valve “3” to drain the water from the sedimenter.
 - ② After draining the condensate, be sure to fasten the drain valve “3” .
- Removing the bowl “4” of the sedimenter shown in the right figure, fuel comes out. Removing the bowl “4” of the sedimenter shown in the right figure, fuel comes out.
 - Drain the condensate in container, and then dispose of condensate according to the designated regulations.

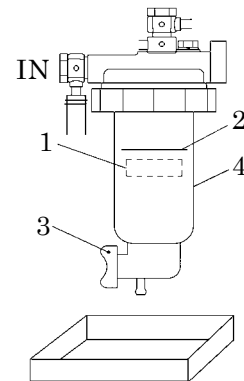

A030159

2. Operation

2.6.10 Check V-Belt Tension

IMPORTANT

- Too tight belt tension could damage shaft and shorten bearing life. Too loose belt tension may result in damaging belt earlier and machine components due to overheat.

Follow the procedure below to adjust tension of fan belt and V-belt for alternator.

[PDS100S,130S-6B4]

(Procedure)

- ① Adjust the tension by gradually loosening the fastening bolt of the alternator.
- ② Visually check if there are any cracks or tears in the belt.
- ③ Loosen the fastening bolt of the alternator until the play of the belt reaches 0.2 to 0.3 in. (6.0 to 8.0 mm) when pushed by fingers, and adjust it.
- ④ Be careful not to leave any grease or LLC * on a belt while changing it. If any such material is left, wipe it off completely.

* Long life coolant

0.2 to 0.3in.[111bf(49N)]

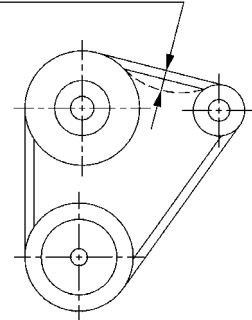

H000041E-2

[PDS185S-6B4]

(Procedure)

- ① Adjust the tension by gradually loosening the fastening bolt of the alternator.
- ② Visually check if there are any cracks or tears in the belt.
- ③ Loosen the fastening bolt of the alternator until the play of the belt reaches 0.43 to 0.51 in. (11.0 to 13.0 mm) when pushed by fingers, and adjust it.
- ④ Be careful not to leave any grease or LLC * on a belt while changing it. If any such material is left, wipe it off completely.

* Long life coolant

0.43 to 0.51in.[221bf(98.1N)]

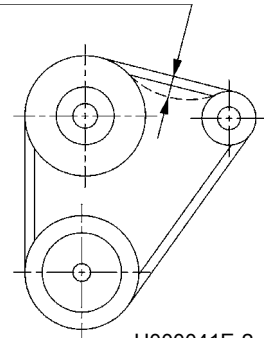

H000041E-2

2. Operation

2.6.11 Check Wiring of Each Part

Check each wiring for any loose connection, damage to insulating sheathed portion, disconnection, and short-circuit.

2.6.12 Check Piping of Each Part

Check each piping for any loose connection and also check each hose and pipe for any tear and leaks.

2.7 Unit Operation



CAUTION

Operation with compressed air supply port opened is prohibited

- Do not operate the machine with service valves and relief valve open unless air hoses and/or pipes are connected. High-pressurized air blows out and its air pressure could cause injury to the people nearby.
- When the machine has to be unavoidably temporarily operated with its port open, be sure to mount a silencer to reduce noise and wear protective materials such as earplugs to prevent damage to hearing.

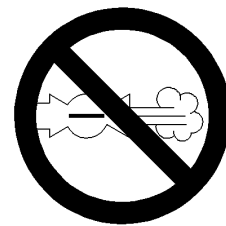

D003

Quick Glow System

- Since this equipment is provided with a quick glow system (quick preheating device), **you do not have to turn the starter switch counterclockwise from STOP position.**
- Turn the starter switch to the “RUN” position, and the preheating will be completed in several seconds and the preheating lamp will go out. Then, turn the Starter Switch to the Start position to start up the engine.
- When the engine is already warm, the preheating operation is automatically omitted. Even though the preheating lamp lights up momentarily, ignore the lamp status, and start up the engine.

WARNING – Because of the quick glow system, never use starting fluids to start engine.

2. Operation

2.7.1 Procedure to Start the Unit

IMPORTANT

———— **Be sure to warm-up** ————

- Be sure to let unit warm-up after starting for smooth operation of the engine and the compressor. Do not operate the engine at full load immediately after it starts up. This will shorten the equipment life.
- During the warm-up operation, examine the different parts of the equipment for any looseness, leakage of water, oil, fuel, and other irregularities.
- Also, make sure that warning lamps are off.

[PDS100S,130S-6B4]

(Procedure)

- ① Close fully service valves “1” .
- ② Set the starting unloader valve “2” to “START” position.
- ③ Turn the starter switch “3” to “RUN” position, and the preheating lamp “4” goes on.
- ④ As soon as the preheating lamp “4” has gone out, turn the starter switch “3” fully clockwise to start up the engine.
- ⑤ Once the engine has started up, leave it running to warm-up for five minutes. The discharge air pressure gauge “5” in this condition ranges from 57 to 100 psi (3.9 to 6.9 bar).
- ⑥ After warm-up of the unit, put the starting unloader valve “2” back to its “RUN” position, and open the service valve “1” . The unit is now ready to operate.

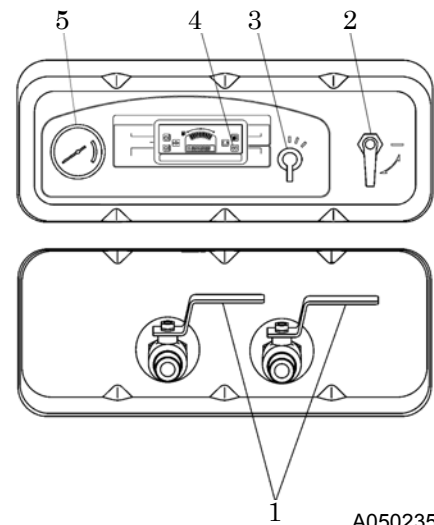

A050235

- Be sure to turn the starting unloader valve “2” to “RUN” position prior to work. The discharge pressure does not increase as long as the starting unloader valve “2” stays at “START” position.

[PDS185S-6B4]

(Procedure)

- ① Close fully service valves “6” .
- ② Set the starting unloader valve “4” to “START” position.
- ③ Turn the starter switch “3” to “RUN” position, and the preheating lamp “5” goes on.
- ④ As soon as the preheating lamp “5” has gone out, turn the starter switch “3” fully clockwise to start up the engine. Hold the starter switch “3” at the “START” position till the oil pressure lamp will be off.
- ⑤ Once the engine has started up, leave it running to warm-up for five minutes. The discharge air pressure gauge “1” in this condition ranges from 57 to 100 psi (3.9 to 6.9 bar).
- ⑥ After warm-up of the unit, put the starting unloader valve “4” back to its “RUN” position, and open the service valve “6” . The unit is now ready to operate.

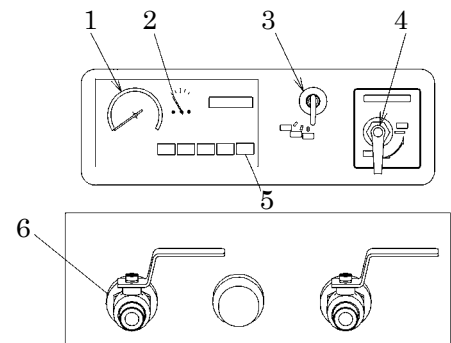

A030156

- Be sure to turn the starting unloader valve “4” to “RUN” position prior to work. The discharge pressure does not increase as long as the starting unloader valve “4” stays at “START” position.

2. Operation

2.7.2 Operating Procedures when Engine Fails to Start up on First Attempt

- When the engine fails to start up even after performing the startup procedures ① to ④, do not keep the starter running, but set the starter switch back to "STOP" and wait about 30 seconds. Then, repeat the startup procedure once again.
- If the repeated procedure does not allow the engine to run, the following causes are suspected. Check the following:
 - No fuel
 - Clogging of fuel filter
 - Clogging of filter inside the fuel air bleeding electromagnetic pump
 - Discharge of battery (Low cranking speed)

2.7.3 EFPA (Electrical Fuel Primer and Air Bleed)

[PDS100S,130S-6B4]

The electromagnet pump automatically bleeds the air remaining in the pipes, after the filter for electromagnet pump and fuel filter element are replaced or after emergency stop due to drop of fuel residual level.

(Procedure)

- ① Turn the starter switch to its "RUN" position. The electromagnetic pump starts pumping and automatically bleeds air caught in the fuel pipes.
 - ② Air-bleeding will be completed within 20 to 30 seconds.
 - ③ Start the machine following the starting procedures mentioned in 2.7.1. If starting fails one time, repeat the abovementioned procedures.
- In case air still remains, loosen air bleeding screw to bleed the air, leaving the starter switch placed "Run" position.
 - After finishing the air bleeding operation, never leave the starter switch placed on "Run" position because the battery is discharging.

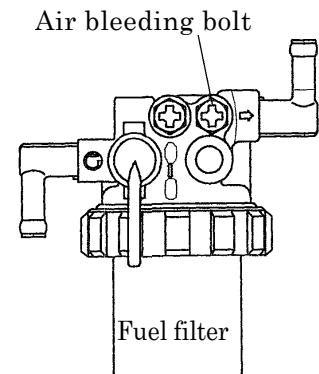

A080607-1

[PDS185S-6B4]

If the unit runs out of fuel, the electromagnetic pump attached to the unit will automatically bleed air out of the fuel system. (After draining sediment from water sedimentor or changing fuel filter with a new one, bleed the air in the same procedure as below.)

(Procedure)

- ① Turn the starter switch to its "RUN" position. The electromagnetic pump starts pumping and automatically bleeds air caught in the fuel pipes.
 - ② Air-bleeding will be completed within 20 to 30 seconds.
 - ③ Start the machine following the starting procedures mentioned in 2.7.1. If starting fails one time, repeat the abovementioned procedures.
- After finishing the air bleeding operation, never leave the starter switch placed on "Run" position because the battery is discharging.

2. Operation

2.7.4 Operation under Cold Weather Conditions

When it is difficult to start engine in cold weather, take the following measures.

(Procedure)

- ① Close all the service valves and fully open the relief valve "1" provided at the front of the separator receiver tank.
- ② When engine starts after performing the startup procedure, gradually close the relief valve, watching the rise of engine revolutions. Then after closing the valve fully, perform warming-up operation in this state.

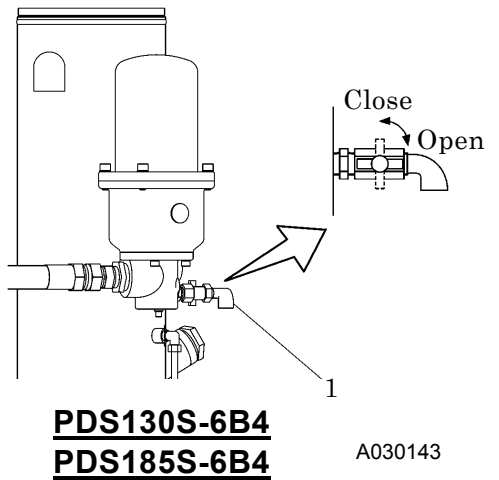

IMPORTANT

— **Operation under Cold Weather Conditions below 23°F (-5°C)** —

- Use SAE10W-30 (CD class) for the engine oil.
- Use LLC (antifreeze). Use correct amount to provide freeze protection, according to the ambient temperature.
- Battery should always be kept fully charged.









2. Operation

2.7.5 Gauge Indication while Operating

IMPORTANT

- Minimum discharge air pressure is 73 psi (5.1 bar) during operation.
- Continuing equipment operation at a lower pressure than the above pressure may cause overheating, since it affects the separation of lubricating oil inside the oil separator and reduces the oil flow to the compressor air-end, resulting in temperature rise.

- Be sure to check at times to see if gauges or each component of the unit are properly working, or if there is any air-leak, oil-leak, water-leak or fuel-leak etc.
- During normal operation, each indication of instruments is shown in the table below. Refer to the table for daily checks.
- The table gives standard values. They may vary slightly depending on the operating conditions and other factors.

Protection device	Emergency stop Lamp			Warning Lamp		Indicator lamp
	Discharge air temperature	Engine oil pressure	Coolant temperature	Fuel residual level (PDS100S-6B4) (PDS130S-6B4)	Charging	Preheating
Monitor						
Starting	Starter switch set to "RUN" position					
	● OFF	 ON	● OFF	● OFF	 ON	● OFF
In Operation	 OFF					

		Discharge air pressure gauge
In Operation	Unload	102 – 128 psi (7.1 – 9 bar)
	Full load	73 – 100 psi (5.1 – 6.9 bar)

Note: The lamp marked with asterisk * goes out when preheating is completed.

2.8 Stopping Procedures

- ① Close the service valve completely and operate the machine about 5 minutes, until it cools down.
 - ② Turn the starter switch to "STOP" position to stop the engine.
 - ③ Remove the key from the compressor every time when you stop the engine.
- Unless all the service valves are fully closed upon stopping operation, the compressed air will be sent in reverse direction in the hoses (pipes) connected to air tools and relieved to atmosphere continuously through the auto-relief valve. Further, when re-starting operation next time, compressed air will be jetted out through service valves.

3. Transportation and Towing the Unit

3.1 Transportation



Transportation

- When loading and unloading unit, be sure to use the lifting bail provided on the center of the unit top.
- Never get under the unit which is lifted up, because it is very dangerous.
- When unit is transferred or moved from working site, be sure to place it on truck bed, and fasten it by ropes at the front eye and rear stand. Also be sure to put a set of chocks to fix its wheels firmly on the truck bed.
- Never lift unit which is still in operation, or it could cause critical damage to each component or lead to serious accident.
- When lifting unit up, make sure that all the fixing bolts on the bonnet are surely tightened because it is feared that the unit may fall.
- If towing unit : Make sure machine is towed level.
- Check tire pressure and tire condition before towing.
- Attach safety chains and use correct tow hitch.
- Check operation of lights and brakes before towing.
- Check wheel lug nuts for proper torque.

Lifting up

Before lifting the unit up, make sure to check the lifting bail “ 2 ” for any crack and loosened bolts.

Connect the hook “ 1 ” of the crane or shackle with lifting bail “ 2 ” eye fitted at the top center of the unit, and make sure that there is no person standing around the unit. Then perform hoisting operation.

Use an auxiliary rope “ 3 ” and communicate with the other personnel using signs and signals while lifting operation, so that no swinging motion or twisting happens to the lifted unit.

Select a truck or a crane with capacity sufficient for weight and size of the unit by referring to the values shown in Chapter 8 “Specifications“ of the manual.

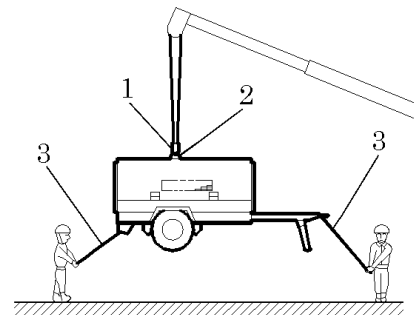

A000053

Lowering the unit from the truck bed pulling down

- Lower the unit down onto a level place which can sustain the weight of the unit.
- After placing the unit down, put chocks to lock the wheels before unfastening the crane's shackles.

3. Transportation and Towing the Unit

3.2 Towing the Unit

 **WARNING**

- Before towing the unit, check the following points and be sure to repair failures, if any:
- Air-pressure in the tires.
- Loose wheel bolts or nuts.
- Abnormal wear or damage to the tires.
- Damage of drawbar.
- Be sure to use a vehicle with enough capacity to tow the unit in operating weight.
- Do not tow the unit without unfastening tool, equipment, and hoses.
Keep hands and fingers clear during hook-up or unhooking drawbar.
- If you do not follow the above instructions, it could cause serious injury or big damage.

4. Installation

4.1 Location and Installation

WARNING

Ventilation

- Exhaust gas from the engine is poisonous, and could cause death when inhaled.
Avoid using the machine in an insufficiently ventilated building or tunnel.
- Do not position the exhaust gas outlet in direction of a person or a house.

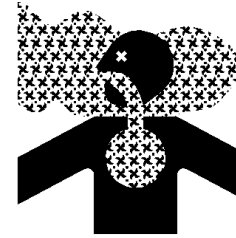

PC002

WARNING

- The machine has to be parked horizontally on a level place.
- In case the machine has to be parked on a slope, place it across grade so that the machine does not tend to roll downhill.
- Grade on a slope shall be within 15 degrees
- Be sure to put one set of chocks " 1 " to the wheels.

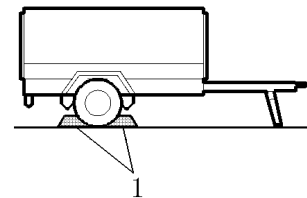

A000054

- The machine should be operated in following conditions:
 - Ambient temperature 5°F to 104°F (-15°C to +40°C)
 - Humidity Less than 90%
 - Altitude Lower than 1,500 m above sea level
- Install the machine in a place with good ventilation, lower temperature and with surroundings as dry as possible.
- If more than two machines are placed parallel in operation, keep enough distance so that exhaust air from one machine does not affect the other one.
- Also, a machine has to be installed in the environment where fresh air is always available.
- Keep enough space around the unit for inspection and maintenance access.

5. Periodic Inspection/Maintenance

5.1 Important Items at Periodic Inspection and Maintenance or after Maintenance

The manual shows proper interval for periodic inspection and maintenance under normally operating conditions. Inspection and maintenance should be performed more often under extremely harsh conditions.



WARNING

Hang a "Now Checking and under Maintenance" tag

- Remove the starter key from the starter switch before starting inspection, and hang up a "Now Checking and under Maintenance" tag where it can be easily seen. The checker must keep the key during checking and maintenance.
- Remove the negative (-) side cable from the battery.
If the above procedure is neglected, and another person starts operating the machine during check or maintenance, it could cause serious injury.
- Use tools appropriate for the inspection and maintenance. Any makeshift or improper tools could cause unexpectedly injury by their slippage.

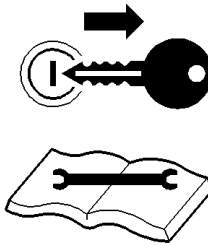

SY001



CAUTION

For protecting oil separator from fire accident

- Be sure to perform oil change basically according to the specified interval. But if such oil is found much more contaminated before the interval, change the oil even before the specified period comes. In doing so, replace the oil completely and use our recommended oil.
- Be sure to perform following periodic inspection and maintenance:
 1. Check and change compressor oil
 2. Change oil separator
- Never mix the oil of different brands, or the mixed oil may deteriorate the oil quality.

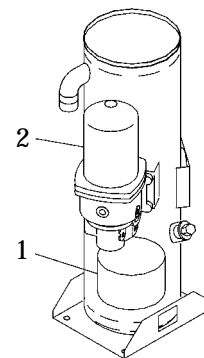

H00046

5. Periodic Inspection/Maintenance

IMPORTANT

Precautions for check and maintenance

- Be sure to use recommended fuel, oil, grease, and antifreeze.
- Do not disassemble or adjust engine, compressor or part(s) for which inspection or maintenance is not referred to in this manual.
- Use genuine parts for replacement.
- Any breakdown, caused by using unapproved parts or by wrong handling, will be out of the scope of "WARRANTY".
- Keep the electrical components away from water or steam.
- Waste from machines contains harmful material. Do not dispose of such harmful fluids to the ground, rivers, lakes or ponds, and sea. It contaminates the environment.
- When draining waste fluid from machines, use leakproof containers to hold such fluids from machine.
- Be sure to follow the designated regulations when disposing of oil, fuel, coolant, filters, battery and other harmful things.

5.2 Daily Inspection and Operation Log

- Be sure to carry out daily inspection every morning before operation. See Chapter 2 "Operation" of the manual for the details of inspection.
- Pay attention to and carefully observe the following points during daily operation or inspection and maintenance work. If any trouble or abnormality is found, immediately investigate its cause and make repairs. If the cause is unknown or not traceable, or if the trouble involves a part or component not described in the manual, ask your nearest dealer for information.

- (a) Controls and instruments function properly.
- (b) Quantity and any leak of water, fuel, and oil or any contamination should be checked.
- (c) Appearance, abnormal noise or excessive heat should be checked.
- (d) Loose bolt or nut should be checked.
- (e) Any damage, wear or shortage of machine components and parts should be checked.
- (f) Performance of each part or component should be proper.

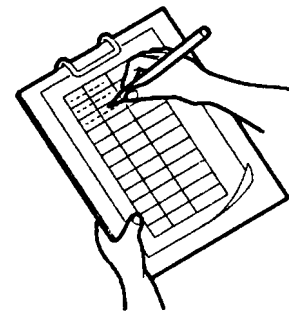

TR0049

- Keep the operation log to record constant inspection of each component, so that trouble of the unit can be easily discovered and preventive measures can be taken.
It is very useful to record information such as discharge pressure, oil level, as well as running hour, maintenance items and replenishment of lubricant on a daily maintenance log.

5. Periodic Inspection/Maintenance

5.3 Periodic Inspection List

(Unit:Hour)

	Maintenance	Daily	Every 250	Every 300	Every 500	Every 1,000	Every 2,000	Every 3,000	Page
Compressor	Check compressor oil level.								2-8
	Drain of separator receiver tank.								2-8
	Check looseness in pipe connecting part, and wear and tear of pipe.								2-12
	Check oil, water, fuel and air leak.								2-15
	Check performance of gauge and indication lamps.								2-15
	Change compressor oil.			1					5-9
	Change compressor oil filter.			1					5-10
	Clean strainer in the scavenging orifice.								5-10
	Clean and change air filter element.		(Clean)		(Change)				5-11
	Clean outside of oil cooler.								5-13
	Change speed regulator diaphragm.								5-12
	Change oil separator.								5-15
	Change nylon tubes.								5-15
	Change unloader of o-ring.								5-16
	Change spacer of unloader.					2			
	Change pressure regulator.								5-16
	Check rubber hoses.								5-16
Check o-ring and needle valve of auto-relief valve.								5-16	

Such items marked shall be carried out by customers.

For the following items or clauses marked , contact us directly or our distributors because they require expert technical knowledge on them.

The following table shows the inspection and maintenance intervals under normal operation conditions. In case the unit is operated under harsh environmental conditions and operation conditions, the intervals should be shortened.

The items or parts marked 1 show that they should be replaced primarily.

The items or parts marked should be replaced every two years even if they are not in disorder within their periodical maintenance interval because their materials will change or become degraded as time passes.

Also for the same reason, the parts marked should be replaced every three years.

Regarding the item marked 2, check the function of the unloader. In case the unloader malfunctions, change O-ring or bushing of unloader. This is because either of both parts may be worn out.

5. Periodic Inspection/Maintenance

◎ Refer to engine operation manual for inspection and maintenance of an engine.

(Unit:Hour)

	Maintenance	Daily	Every 50	Every 250	Every 500	Every 1,000	Every 2,000	Every 3,000	Every 8,000	Page
Engine	Drain fuel tank (Including sedimenter).	○								2-9
	Check fuel.	○								2-9
	Check engine oil level.	○								2-7
	Check coolant level.	○								2-7
	Check looseness in pipe connectors, terminals and tear in wiring.	○								2-12
	Check V-belt tension.	○								2-11
	Change engine oil.		※○	○						5-7
	Change engine oil filter.		※○		○					5-8
	Check battery electrolyte.			○						5-8
	Clean and change air-filter element.			○ (Clean)	○ (Change)					5-11
	Change fuel filter.				○					5-11
	Change filter for air bleeding electromagnetic pump.				○					5-12
	Change coolant.					☆○				5-14
	Clean inside of radiator.					○				5-13
	Clean outside of radiator.					○				5-13
	Change rubber hose.						★●			5-15
	Clean inside of fuel tank.						●			5-15
Change radiator hoses.							★●		5-16	

The items or parts marked ※ show that they should be replaced primarily.

The items or parts marked ☆ should be replaced every two years even if they are not in disorder within their periodical maintenance interval because their materials will change or become degraded as time passes.

Also for the same reason, the parts marked ★ should be replaced every three years.

5. Periodic Inspection/Maintenance

5.4 Periodic Replacement of Parts

5.4.1 Filters

Part Name		Part Number	Quantity	
Engine oil filter	PDS100S-6B4	SHIBAURA 140517020	1	
	PDS130S-6B4	SHIBAURA 140517020	1	
	PDS185S-6B4	NISSAN 15208 43G00	1	
Compressor oil filter		37438 05201	1	
Air filter element	PDS100S-6B4	32143 11700	1	
	PDS130S-6B4	32143 11800	1	
	PDS185S-6B4	32143 12700	1	
Fuel filter	Element "4"	PDS100S-6B4	SHIBAURA 360720060	1
	O-ring "5"		SHIBAURA 052100440	1
	Element "4"	PDS130S-6B4	SHIBAURA 360720060	1
	O-ring "5"		SHIBAURA 052100440	1
	Element	PDS185S-6B4	NISSAN 16403 J5500	1
Oil separator	Separator	34220 12801	1	
	O-ring	03402 15140	1	
Filter for electromagnetic pump	PDS100S-6B4	43540 08000	1	
	PDS130S-6B4	43540 08000	1	
	PDS185S-6B4	43540 05600	1	

5.4.2 Diaphragms & O-Rings

Part Name		Part Number	Quantity
Diaphragm of speed regulator		36437 01500	1
Pressure regulator		36400 19000	1
Auto-relief valve	O-ring "1"	03402 25021	1
	O-ring "2"	03402 25008	1
	O-ring "3"	21221 02100	1
	Needle valve "4"	36429 00800	1
O-ring of unloader		21441 03000	1

5. Periodic Inspection/Maintenance

5.5 Items and Places of Inspection

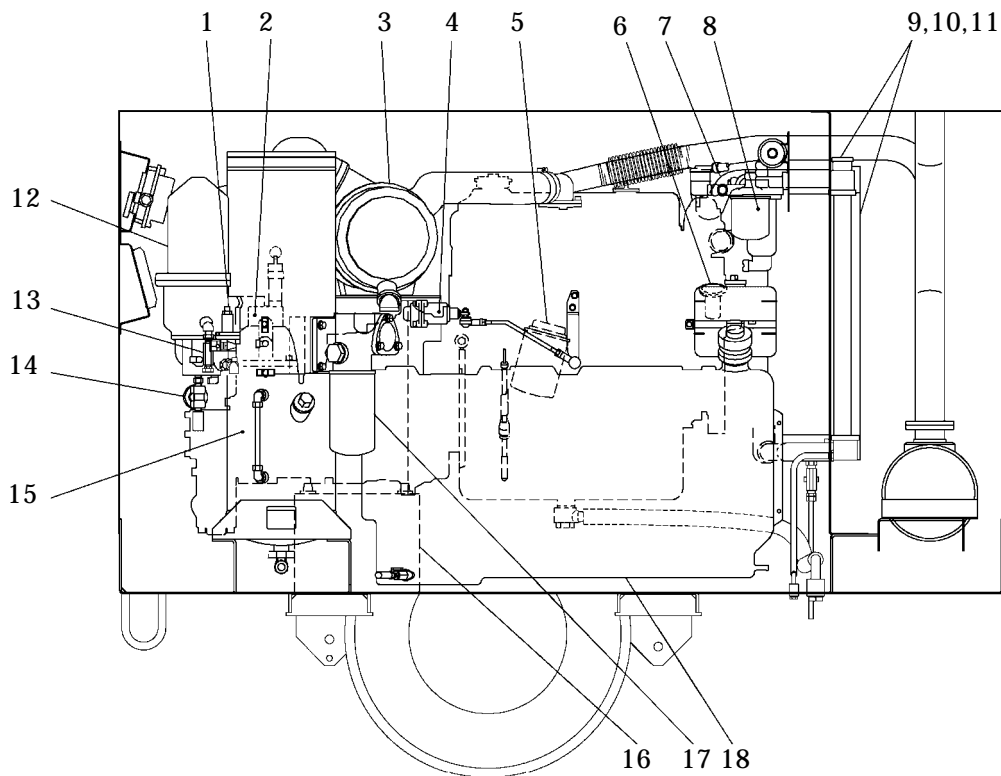

PDS185S-6B4

A030139

1. Change pressure regulator
2. Change O-ring of unloader
3. Change air filter element
4. Change diaphragms of speed regulator
5. Change engine oil filter
6. Change engine oil
7. Change radiator hoses
8. Change fuel filter
9. Clean outside of the radiator and oil cooler
10. Clean inside the radiator
11. Change coolant
12. Change oil separator
13. Clean strainer in the scavenging orifice
14. Check O-ring and needle valve in the auto-relief valve
15. Change compressor oil
16. Check battery
17. Change compressor oil filter
18. Clean inside the fuel tank
 - Change nylon tubes
 - Change rubber hoses and pipes

5. Periodic Inspection/Maintenance

5.6 Maintenance Items

5.6.1 Change Engine Oil

- At 50 hours for the first change and at every 250 hours thereafter



Caution in filling or discharging engine oil

- After stopping the engine, wait for 10 to 20 minutes until the engine oil cools off. Then check the level of the engine oil, or refill or drain the oil.
- Engine oil is very hot and highly pressurized during or just after the operation. Hot oil could blow out of the tank and can cause scalding.



H990432

IMPORTANT

How to choose engine oil

- Be sure to use oil equivalent or superior to CD class engine oil. (Using engine oil with poor quality may shorten the life of the engine.)
- Viscosity of engine oil greatly affects startability, performance, oil consumption of the engine, as well as wear of the moving parts.
- Choose appropriate oil based upon the table below according to the outside air temperature.

Relation between viscosity (SAE) and temperature

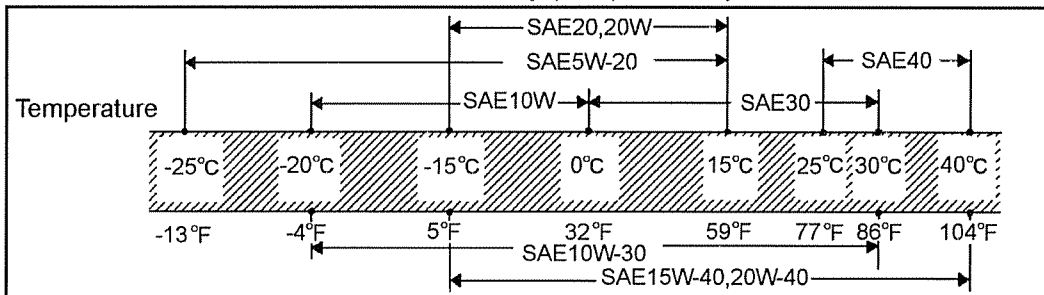

- When two or more different brands of oil are mixed, its performance can be deteriorated. Do not mix oils.
- Follow the designated regulations to dispose of engine oil.

(Procedure)

- ① Loosen the drain plug "2" located outside of the frame to drain out the used oil.
- ② When the oil is completely drained, close the drain plug "2" firmly and refill new engine oil through the engine oil filler "1".

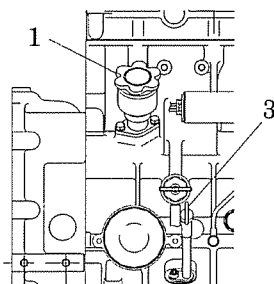

A040308

PDS100S,130S-6B4

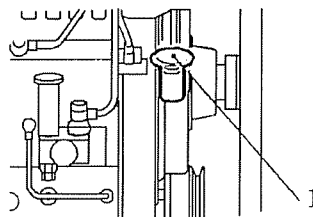

A000065

PDS185S-6B4

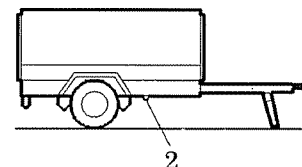

H000048E

PDS100S,130S-6B4 : Pull the engine oil dipstick "3"

out to release air from the engine inside when you refill the engine oil. Otherwise, it will cause the engine oil to overflow from the oil port.

5. Periodic Inspection/Maintenance

5.6.2 Change Engine Oil Filter

- At 50 hours for the first change and at every 500 hours thereafter

(Procedure)

- ① When new oil filter "1" is installed, spread oil over the packing "2", and then screw it in the housing. When the packing touches the sealing surface, further tighten the filter by turning it 3/4 revolutions by using a filter wrench.
 - ② After the oil filter "1" is assembled, check if there are any oil leaks during operation.
- For replacement parts, refer to 5.4.1.

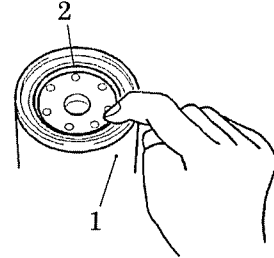

H000049

5.6.3 Check Battery electrolyte

- Every 250 hours

If there seems to be a problem in starting an engine due to a dead battery, carry out the checks by following the procedures below:

1. Ordinary type battery:

Measure specific gravity of battery electrolyte, and if it shows below 1.24, recharge the battery immediately.

Refer to 6.2. for method of specific gravity measurement and recharging the battery.

2. Enclosed type battery:

Check the indicator on top surface of the battery.

If the indicator shows that charge is needed, recharge the battery immediately.

5.6.4 Check and Clean Air Filter Element

- Every 250 hours

IMPORTANT

— *Cleaning of Air Filter Element should be perfectly performed* —

- Clogged or cracked or pitted element could allow entrance of dust into engine and compressor to cause earlier wear of moving parts. Periodical inspection and cleaning of element should be performed to maintain life of compressor and engine long.

- Remove element "1" and clean it.
- In case you attach the cup "2" after element cleaning, please push into a case "3" firmly by hand, and fasten after checking having applied the hook of the handle for cup fixation to the case "3"
- When it is found difficult to restore the element by cleaning it, replace it. (See 5.6.8)

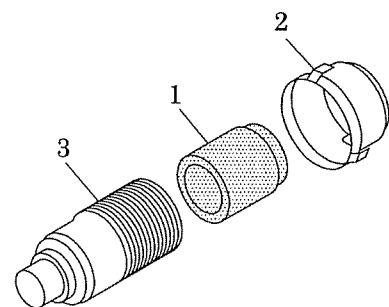

H000051

5. Periodic Inspection/Maintenance

5.6.5 Change Compressor Oil

- At 300 hours for the first change and every 500 hours thereafter



Refilling of compressor oil

- When you refill the separator receiver tank with compressor oil, stop the engine, and make sure that the pressure gauge indicates 0 psi (0 bar) and there is no residual pressure in it, and then gradually loosen the oil filler cap for refilling oil.
- Note residual pressure in the receiver tank could force both extremely hot compressed air and oil to jet out and you may be scalded or seriously injured.

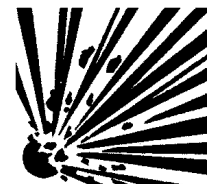

W010

IMPORTANT

—— *Do not mix compressor oil* ——

- Be sure to use recommended oil listed below.
- Viscosity of the oil varies depending on the temperature and other environmental conditions.
- Select one from the recommended oil listed below.

Maker and Brand of Recommended Oil

Maker	Brand
HULS	ANDEROL 3032
MOBIL	RARUS SHC 1024
TEXACO	SYN-STAR DE32

- Even continuous oil replenishment cannot improve its deteriorated condition. Be sure to change the oil completely at every scheduled interval.
- Do not mix it with other brand oil, or it will cause poor performance and shorten the life of the compressor oil. (But fresh compressor oil could accept a mixture of small amount of different brands.)
- Running the unit with old and deteriorated compressor oil will cause damage to bearings, or serious accident like ignition in a separator receiver tank. Be sure to change the oil completely at every scheduled interval.
- Follow the designated regulations to dispose of compressor oil.

5. Periodic Inspection/Maintenance

(Procedures)

- ① Remove the oil filler cap “3” of separator receiver tank “1” .
- ② Open drain valve “2” to discharge waste oil from the tank.
- ③ In case of replacement, completely discharge all the oil left in the compressor body, separator receiver tank “1” , pipes and oil cooler. If wasted oil is left in the unit, this residual oil will greatly shorten the life of the newly replenished oil.
- ④ Be sure to close drain valve “2” after the wasted oil is completely discharged.
- ⑤ Fill the designated quantity of new oil into the oil filler port.
- ⑥ After oiling, tighten the cap “3” in its place while paying attention not to let dust get in the tank.
- ⑦ Start the engine for a short while, then replenish the oil to fill shortage. Repeat this procedure for 2 to 3 times to check if the oil level has reached its appropriate point. Be careful not to overfill the oil.

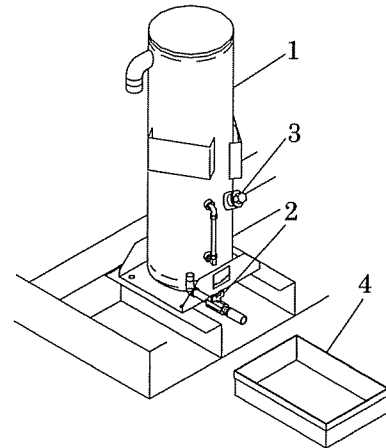

H000038

5.6.6 Change Compressor Oil Filter

- At 300 hours for the first change and every 1,000 hours thereafter

IMPORTANT

Use our genuine oil filter

- Poor quality oil filters do not trap dust sufficiently and will cause damage to the bearings in a short period.

(Procedure)

- ① Use a filter wrench to remove the cartridge “1” .
 - ② Spread thin film of oil on a packing “2” of a new cartridge “1” and screw it in.
 - ③ After a packing touches the sealing face, tighten it 3/4 or one time turn, using filter wrench.
 - ④ After installing oil filter, be sure to check for oil leak during the operation.
- For replacement parts, refer to 5.4.1.

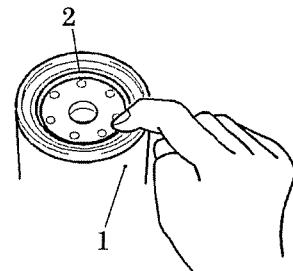

H000049

5.6.7 Clean Strainer in the Scavenging Orifice

- Every 500 hours

Wash the strainer “1” with solvent, and blow off the “dust” with air.

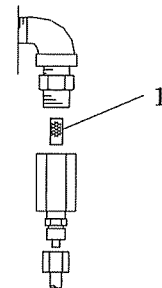

H000050

5. Periodic Inspection/Maintenance

5.6.8 Change Air Filter Element

- Every 500 hours

IMPORTANT

— Use our genuine part —

- Air filter is an important part which is crucial to machine's performance and life. Be sure to use genuine parts.

- Even before 500 hours of use, if it is used under harsh conditions, remove the element "1", check and clean it. If it is found difficult to restore it, change it a little earlier.
- For replacement parts, refer to 5.4.1.
- In case you attach the cup "2" after element change, please push into a case "3" firmly by hand, and fasten after checking having applied the hook of the handle for cup fixation to the case "3".

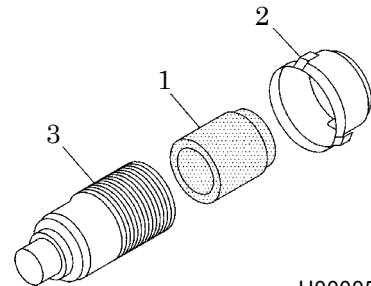

H000051

5.6.9 Change Fuel Filter

- Every 500 hours

[PDS100S,130S-6B4]

(Procedure)

- ① Turn the lever "1" of "FUEL VALVE" of fuel filter to the direction of "CLOSE" mark to cut off the fuel flow.
 - ② Loosen the ring nut "2" to remove cup "3", take out the element "4".
 - ③ Clean the cup "3", fit a new element "4" in, and install a new packing "5" to the ring nut "2".
 - ④ After installing the cup "3" with the element "4" built in to the body, securely fasten it by the ring nut "2".
 - ⑤ After pouring the fuel into the cup by turning the lever "1" of "FUEL VALVE" to the direction of "OPEN", bleed the air. (See 2.7.3)
- For replacement parts, refer to 5.4.1.

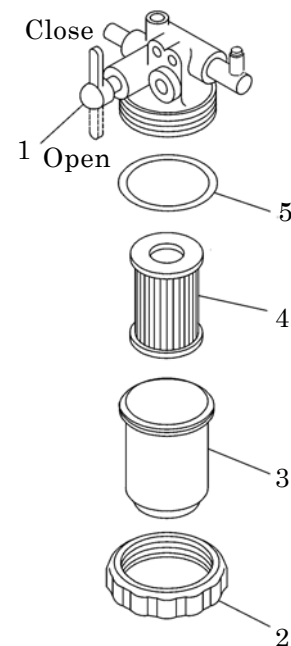

A050084

[PDS185S-6B4]

(Procedure)

- ① Remove cartridge "1" using a filter wrench.
 - ② To install a new fuel filter, apply a thin coat of fuel to the packing and then screw it in.
 - ③ When the packing is brought in contact with the seal surface, tighten it by giving it 2/3 turns with a filter wrench.
 - ④ After the fuel filter is installed, check for fuel leak during operation.
 - ⑤ Bleed air out of fuel line. (See 2.7.3)
- For replacement parts, refer to 5.4.1.

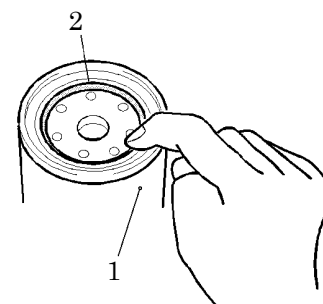

H000049

5. Periodic Inspection/Maintenance

5.6.10 Change Filter for Air Bleeding Electromagnetic Pump

- Every 500 hours
- Remove hose clip “1” and pull out hose “2” from filter “3” .
- When disassembling prepare a saucer to receiver fuel leaking from hose “2” beforehand.
- Replace filter “3” by a new one. (For replacement parts, refer to 5.4.1.)

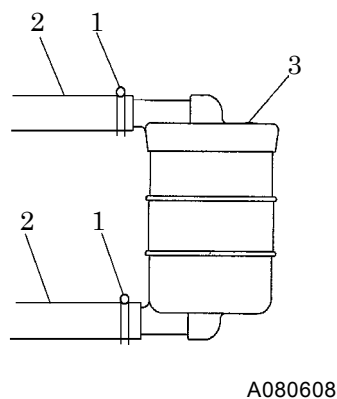

PDS100S.130S-6B4

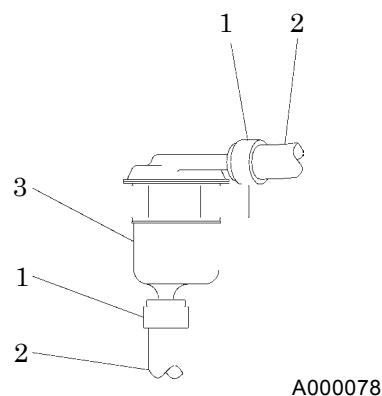

PDS185S-6B4

5.6.11 Change Speed Regulator Diaphragm

- Every 1,000 hours
- <Caution during diaphragm replacement>
- When installing diaphragm “1” , be sure to use the special jig to prevent it from twisting.
 - Before installing diaphragm “1” , be sure to apply molybdenum disulfide (paste spray) to inside and outside of the diaphragm “1” .
 - Install it so that its outside surface should be rubber and its inside cloth.
 - For replacement parts, refer to 5.4.2.

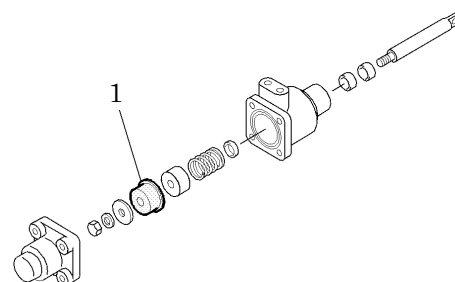

H000053

5. Periodic Inspection/Maintenance

5.6.12 Clean outside of Radiator and Oil Cooler

- Every 1,000 hours
- When the fin tubes “1” of a radiator and an oil cooler are clogged with dust or other foreign materials, the heat exchange efficiency drops and this will raise coolant temperature and discharge air temperature. These tubes and fins should be cleaned depending on the state of clogged fin tubes “1” even before 1,000 hours maintenance schedule.
- Do not use a high pressure washer to protect fin tubes from being damaged.

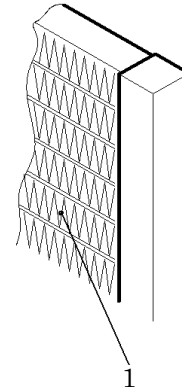

H000054

5.6.13 Clean inside of Radiator

- Every 1,000 hours
- When the inside of a radiator and water conduits of an engine are dirty with scale and rust, its cooling efficiency will be deteriorated. Clean the interiors of such components periodically.
- Ask your nearest dealer for such inner cleaning.

5. Periodic Inspection/Maintenance

5.6.14 Change Coolant

- Every 1,000 hours or every 2 years

CAUTION

Taking off the radiator cap

- Be sure to stop the machine and allow time to cool. Then loosen the radiator cap one notch. After the coolant water is sufficiently cooled and the inner pressure is released, take the cap off. If this procedure is neglected, the inner pressure can blow off the cap. Steam jetting out of the radiator could result in causing scalding. Follow this procedure under all circumstances.



H990432

CAUTION

How to handle LLC (Antifreeze)

- LLC (Antifreeze) is a toxic material.
- When a person has ingested LLC (Antifreeze) by accident, seek medical attention immediately.
- When a person gets LLC (Antifreeze) in his eyes, wash the eyes with clean running water and make him see a doctor immediately.
- When LLC (Antifreeze) is stored, put it in a container with an indication saying “LLC (Antifreeze) inside” and seal it up, then keep it in a place away from children.
- Beware of flames.

IMPORTANT

Quality of coolant and antifreeze

- Use soft water of good quality such as tap water for coolant.
- When water with dirt, sand, and/or dust contained, or hard water such as well water (ground water) is used, this will cause deposits inside radiator or on cylinder head, and will cause engine overheat due to poor flow of coolant.
- When replacing coolant, be sure to install a coolant filter and add coolant.
- When the unit is used in a cold region and possible freezing is expected, it is recommended to use LLC (Antifreeze) for the coolant.
- Adjust mixing ratio of LLC (Antifreeze) with water according to the temperature.
- Use LLC (Antifreeze) within the range of its mixing ratio between 35 and 60%.
(Upon delivery from the works, LLC density is 55%)
- If LLC (Antifreeze) in the water exceeds more than 60%, it may decrease its antifreezing effect.
- Follow the designated regulations to dispose of LLC (Antifreeze).

5. Periodic Inspection/Maintenance

(Procedure)

- ① To drain coolant, first unfasten and take off the cap “1” of the radiator, then remove the drain plug “2” .
- ② Loosen the drain valve “3” provided on engine to drain engine.
- ③ When the drainage has been completed, fasten drain plug “2” and drain valve “3” again, and fill coolant into the radiator through its filler port.
- ④ After changing the coolant, operate the machine for 2 to 3 minutes at the unloaded condition and stop it. Then check the coolant level again, and replenish if it is short.

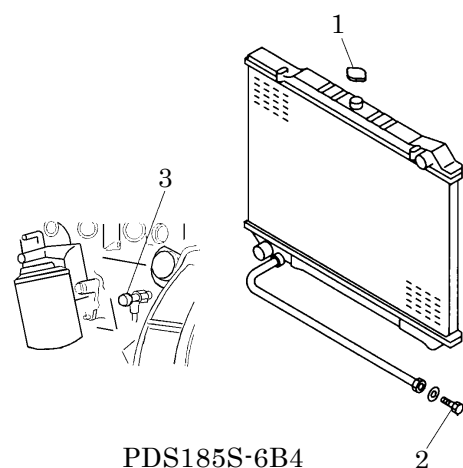

A000066

5.6.15 Clean inside of Fuel Tank

- Every 2,000 hours

Ask your nearest dealer for cleaning the inside of fuel tank.

5.6.16 Change Oil Separator

- Every 2,000 hours
- If even before scheduled interval of 2,000 hours operation, consumption of compressor oil is unusually high, some oil is found in discharged air, replace the oil separator.
- When changing oil separator “1” , be sure to replace cover “2” , element “3” and O-ring “4” .
- Ask your nearest dealer for replacing oil separator.
- For replacement parts, refer to 5.4.1.

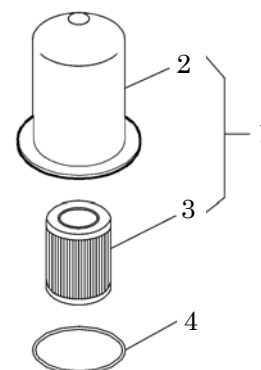

H000056

5.6.17 Change Nylon Tubes

- Every 2,000 hours
- Replace nylon tubes used for the oil and air pipings.
- Ask your nearest dealer for its replacement.

5.6.18 Change Rubber hose

- 2,000 hours or every 3 years
- In case various rubber hoses for fuel system and engine lubrication system are hardened or deteriorated, replace them even before the specified replacement time.
- Replacement of the hoses requires expert technical knowledge. So contact directly us or distributor.

5. Periodic Inspection/Maintenance

5.6.19 Change Pressure Regulator

- Every 3,000 hours
- Remove pressure regulator and rebuild or replace with a new unit.
- For replacement parts, refer to 5.4.2.

5.6.20 Check Hoses

- Every 3,000 hours or every 3 years
- Check hoses used for oil piping for any crack or tear, and replace when an abnormality is found.
- Ask your nearest dealer for replacing hoses.

5.6.21 Change Radiator Hoses

- Every 3,000 hours or every 3 years
- When any crack or wear is found on the hoses, change it even before the scheduled time.
- Ask your nearest dealer for replacement radiator hoses.

5.2.22 Check O-ring and Needle Valve of Auto-relief Valve

- Every 3,000 hours or every 3 years
- Disassemble and clean the component, and check O-ring “1” , “2” , “3” and needle valve “4” . Then, replace O-ring “1” , “2” , “3” and rubber on the valve “4” , if hardened.
- For replacement parts, refer to 5.4.2.

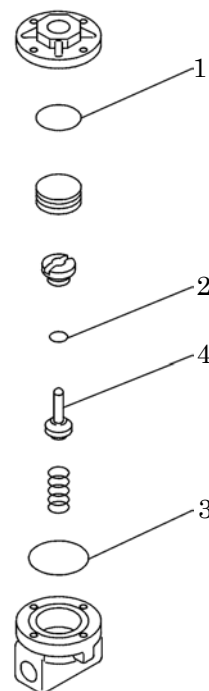

A000057

5.6.23 Change O-Ring of Unloader

- Every 3,000 hours or every 3 years
- <Caution during O-ring replacement>
Supply grease to O-ring “1” after replacement.
Grease: CALTEX MULTIFAX EP1
- For replacement parts, refer to 5.4.2.

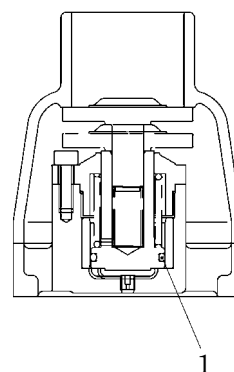

A030158

6. Maintenance/Adjustment

6.1 Adjustment of Regulator



Do not run the compressor with compressed air supply port open

- When adjusting the regulator, be sure to mount a silencer at the discharge opening to eliminate sound. Wear protective materials such as earplugs to prevent hardness of hearing.

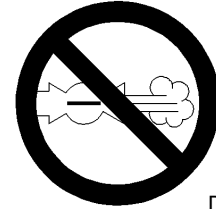

D003

- Regulator is pre-adjusted at delivery from the plant. Never turn the bolt and rod. Otherwise it leads to maladjustment.
- In accordance with the following adjustment procedures, make sure to set engine revolutions to make governor lever contact high-speed stopper at full load. If the pressure in separator receiver tank with engine speed set lower than rated speed drops lower than 44 psi (3 bar) discharge air temperature could rise so much to cause a serious trouble.
- Be sure to follow the procedure below when the component is required to be re-adjusted (such as when the unit has been disassembled).
- Ask your nearest dealer if you have any questions.

(Procedure)

Stop the compressor and adjust the length of the rod "3" which is connected to the speed regulator "2" until its engine governor lever "1" is pulled fully to its high-speed side. (By shortening length of "L", the regulator increases high-speed.) If the engine governor lever "1" does not reach the end of stopper "4" at its high-speed side, sufficient speed of the engine, at its full-load condition, cannot be obtained. There is no need for unload revolution readjustment.

Adjust the pressure regulator "5" by turning its pressure adjustment screw "6", so that the speed regulator "2" starts its actuation and decreases the engine speed when the pressure exceeds 100 psi (6.9 bar). (Pressure increases by tightening the screw, and decreases by loosening the screw.)

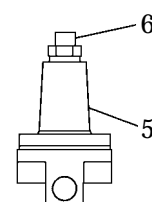
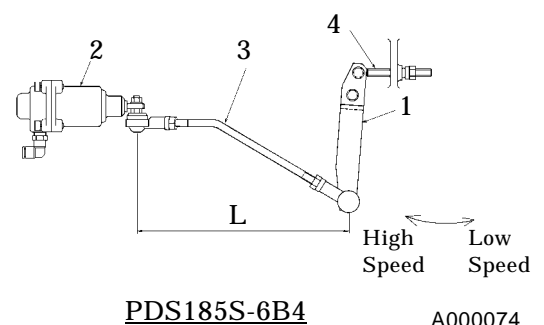
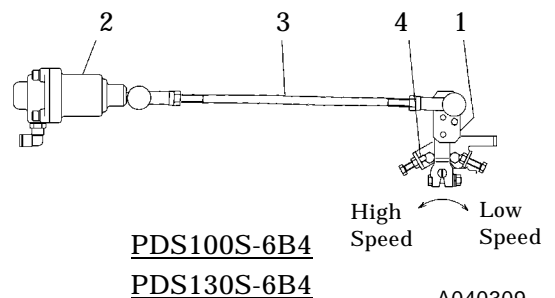

H000059

6. Maintenance/Adjustment

6.2 Maintenance of Battery



WARNING

Handling battery

- Keep flames away from battery.
- Battery generates hydrogen gas and may explode.
- Therefore, recharging should be done at a well-ventilated place.
- Do not allow sparks or flame near the battery.
- Do not check the battery by short-circuiting the positive and negative terminals.
- Never operate the machine nor charge the batteries with the battery liquid level being kept lower than the "LOWER" level. Continuing operation at this lower level will cause deterioration of such parts as pole plates etc., and also it may cause explosion as well as reduction of battery life. Add distilled water so that the liquid level may reach the middle level between the "UPPER" and "LOWER" level without any delay.
- Do not charge a frozen battery. Otherwise it may explode. If the battery is frozen, warm it up until the battery temperature becomes 61°F to 86°F (16°C to 30°C).
- Battery electrolyte is dilute sulfuric acid.
In case of mishandling, it could cause skin burning.
- When you deal with a battery, please be sure to wear protection implements, such as protection glasses and a glove.
- When such battery electrolyte contacts your clothes or skin, wash it away with large amount of water immediately.
- If the battery electrolyte gets into your eyes, wash it away immediately with plenty of water and seek medical attention.
- Dispose of battery, observing local regulations.



D004

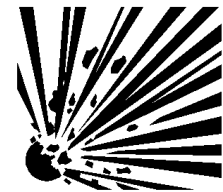

W010



TR0093



CAUTION

Do not connect the cables backwards

- If a booster cable has to be used or when cables are connected at battery replacement, be careful not to connect (+) and (-) terminals backwards. A wrong-connection will cause spark and damage components. Explosion may result.

6. Maintenance/Adjustment

6.2.1 Charge Battery

- Disconnect the cable between battery and the unit, and charge the battery with a 12V battery charger. Do not charge two batteries at the same time.
- Be sure not to connect (+) and (-) terminals backwards.
- Be sure to read the operation manual of the battery charger to know if it is applicable, before using it.

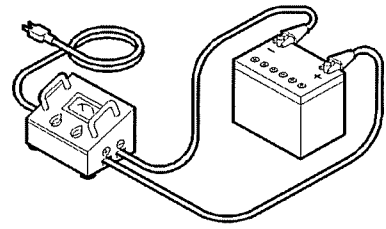

A030594

6.2.2 How to Use Booster Cable



Do not connect the cable reversely

- If a booster cable has to be used or when cables are connected at battery replacement, be careful not to connect (+) and (-) terminals backwards. Such a wrong-connection will cause spark and damage each component.

(Procedure for using a booster cable)

- ① Stop the engine.
- ② Connect one end of the (+) cable to the (+) terminal of the machine battery.
- ③ Connect the other end of the (+) cable to the (+) terminal of the 12V battery used to start the engine.
- ④ Connect one end of the (-) cable to the (-) terminal of the 12V battery.
- ⑤ Connect the other end of the (-) cable to the engine block of the machine.
- ⑥ Start up the engine.
- ⑦ Disconnect the booster cable by following the procedure back in the reverse order.

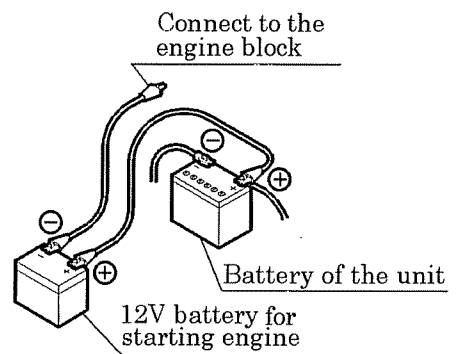

A030595E

6. Maintenance/Adjustment

Symptom	Cause	Countermeasures
Engine oil pressure lamp goes on.	(1) Engine oil shortage. (2) Engine oil filter clogging. (3) Malfunction of engine oil pump (4) Faulty oil pressure switch. (5) Loosened or disconnected wiring or connector.	Replenish oil Change Change Change Check/Fasten
Coolant temperature lamp goes on.	(1) Radiator clogging. (2) Faulty thermostat. (3) Faulty coolant temperature switch. (4) Shortage of coolant. (5) Slippage of fan belt. (6) Looseness, disconnection of wiring or connectors.	Clean Change Change Replenish Adjust tension Check/Fasten
Discharge air temperature lamp goes on.	(1) Oil cooler clogging. (2) Oil filter clogging. (3) Faulty discharged air temperature switch. (4) Looseness, disconnection of wiring or connectors. (5) Slippage of fan belt. (6) Shortage of compressor oil. (7) Malfunction of by-pass valve.	Clean Change Check/Change Check/Fasten Adjust tension Replenish oil
Fuel residual level lamp goes on.	(1) Fuel runs short. (2) Malfunction of sending unit for fuel oil level drop. (3) Loosened and disconnected wiring connection and connectors.	Add fuel oil Inspect/replace Inspect/retighten

- Contact your nearest dealer if you find it difficult to repair by yourselves.
- Refer to the engine operation manual for trouble concerning the engine.

6. Maintenance/Adjustment

6.3 Troubleshooting

- Should any trouble occur during operation, do not leave it. Investigate the cause and take appropriate measures.
- Read the manual carefully and fully understand what to do in case of trouble.
- The better you understand the construction and function of the unit, the faster you can find a problem and solution.
- This chapter describes the state, cause and countermeasures of important troubles in detail:

Symptom	Cause	Countermeasures
Low starter revolution speed.	(1) Battery malfunction.	Check battery Charge, change
Starter rotates but engine does not start.	(1) Fuel filter clogging. (2) Malfunction of fuel cut solenoid or motor stopper. (3) No fuel.	Disassemble, clean, and change Check fuse Change solenoid or motor stopper Check connector Replenish fuel
Discharge air pressure does not reach 100 psi (6.9 bar).	(1) Pressure regulator insufficient adjustment. (2) Starting unloader valve is left at its start position.	Re-adjust (Fasten) Place it at "RUN" position
Engine does not reach its maximum speed.	(1) Improper length in speed regulator rod. (2) Unloader orifice clogging. (3) Faulty speed regulator. (4) Engine trouble. (5) Fuel filter clogging.	Re-adjust Disassemble/Clean Disassemble/Check Call your nearest dealer Disassemble/Change
Revolution drops before discharge air pressure reaches 100 psi (6.9 bar).	(1) Pressure regulator insufficient adjustment. (2) Trouble of pressure regulator. (3) Unloader orifice clogging.	Re-adjust (Fasten) Change Disassemble/Check
Engine does not reach minimum revolution at unload.	(1) Improper length in speed regulator rod. (2) Faulty speed regulator.	Re-adjust Disassemble/Check
Safety valve relieves at unload.	(1) Pressure regulator insufficient adjustment. (2) Speed regulator diaphragm damaged. (3) Unloader valve damaged and seat malfunction. (4) Faulty safety valve. (5) Improper length of speed regulator rod.	Re-adjust (loosen) Change Change Change Re-adjust (elongate)
Oil mixes in Air. (Poor oil separation)	(1) Scavenging orifice strainer clogging. (2) Excessive oil in tank. (3) Low discharge pressure. (4) Oil separator deteriorated.	Disassemble/Clean Drain to its proper level Disassemble unloader/Check Disassemble/Change
Insufficient free air delivery.	(1) Air filter element clogging. (2) Unloader valve cannot fully open. (3) Engine does not reach rated speed.	Clean element or change Call your nearest dealer See 6.1.

7. Storage of the Unit

7.1 Preparation for Long-term Storage

When the unit is to be kept unused in storage for a long time, be sure to follow the preparations below and put the unit in a dry and less dusty place.

- Put the unit in a temporary cabin if it is stored outside. Avoid leaving the unit outside with a sheet cover directly on the paint for a long time, or this will cause rust to the unit.
- Perform the following treatments at least once every three months.

(Procedure)

Drain existing lubricant from the engine oil pan. Pour new lubricant in the engine to clean its inside. After running it for a while, drain it again.

Spread lubricant on moving parts like speed regulator and rod end, beforehand.

Completely charge the battery and disconnect grounding wires. Remove the battery from the unit, if possible, and store it in a dry place. (Charge the battery at least once every month.)

Drain coolant and fuel from the unit.

Seal the engine, air-intake port and other openings like the muffler with a vinyl sheet, packing tape, etc., to prevent moisture and dust from getting in the unit.

Be sure to repair any trouble and maintain the unit so that it will be ready for the next operation.

8. Specifications

8.1 Compressor Specifications

PDS100S-6B4

General Specifications	Overall length	in. (mm)	106 (2,680)	Compressor	Type		Single-stage oil cooled, screw type compressor
	Overall length (bonnet only)	in. (mm)	62 (1,580)		Free air delivery	cfm (m ³ /min)	100 (2.85)
	Overall width	in. (mm)	57 (1,450)		Working pressure	psi (bar)	100 (6.9)
	Overall height	in. (mm)	55 (1,395)		Lubricating system		Forced lubrication by compressed pressure
	Net dry mass	lb (kg)	1,742 (790)		Driving system		Direct driving with gear coupling
	Operating mass	lb (kg)	1,907 (865)		Receiver tank capacity	cu in. (m ³)	1,833 (0.030)
	Fuel tank capacity	gal. (L)	18.5 (70)		Lubricating oil capacity	gal. (L)	3.7 (14)
				Engine	Model		SHIBAURA S773L-C
					Type		Water-cooled 4-cycle swirl chamber type
					Number of cylinders, bore stroke	in. (mm)	3-3.03in. × 3.19in. 3-77mm × 81mm
					Total displacement	cu in. (L)	69 (1.131)
					Rated output	hp/rpm (kW/min ⁻¹)	27.1/3,425 (20.2/3,425)
					Lubricating oil capacity	gal. (L)	1.3 (4.9)
					Coolant capacity (including radiator)	gal. (L)	1.2 (4.5)
			Battery		80D26R (12V) equivalent		

Outline drawing

Unit:in.(mm)

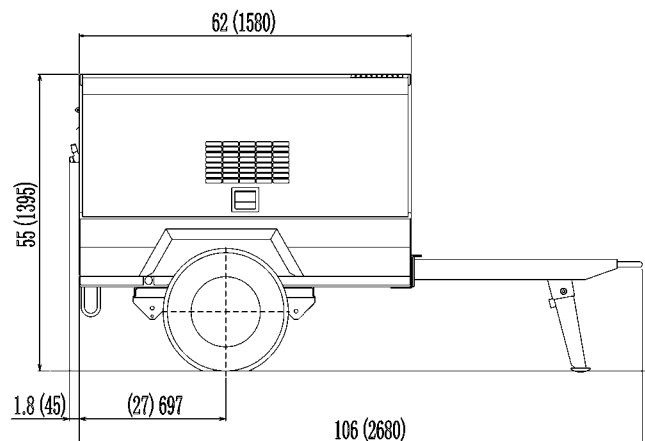
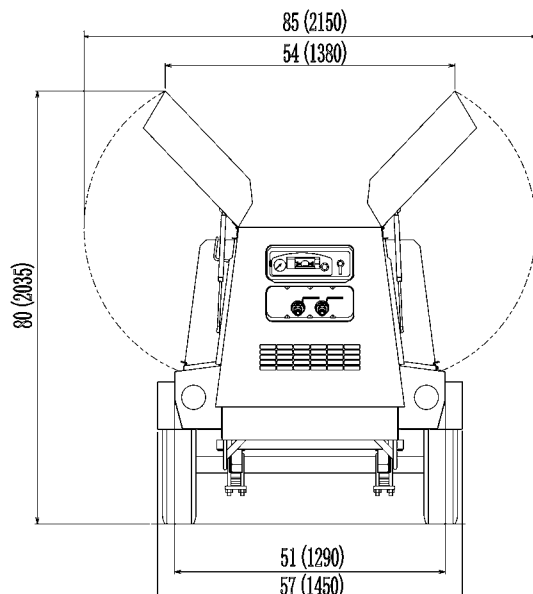

A050236

8. Specifications

PDS130S-6B4

General Specifications	Overall length	in. (mm)	106 (2,680)	Compressor	Type		Single-stage oil cooled, screw type compressor
	Overall length (bonnet only)	in. (mm)	62 (1,580)		Free air delivery	cfm (m ³ /min)	130 (3.7)
	Overall width	in. (mm)	57 (1,450)		Working pressure	psi (bar)	100 (6.9)
	Overall height	in. (mm)	55 (1,395)		Lubricating system		Forced lubrication by compressed pressure
	Net dry mass	lb (kg)	1,940 (880)		Driving system		Direct driving with gear coupling
	Operating mass	lb (kg)	2,116 (960)		Receiver tank capacity	cu in. (m ³)	1,833 (0.030)
	Fuel tank capacity	gal. (L)	18.5 (70)		Lubricating oil capacity	gal. (L)	3.7 (14)
				Engine	Model		SHIBAURA N843L-C
					Type		Water-cooled 4-cycle swirl chamber type
					Number of cylinders, bore stroke	in. (mm)	3-3.31in. × 3.94in. 3-84mm × 100mm
					Total displacement	cu in. (L)	101 (1.662)
					Rated output	hp/rpm (kW/min ⁻¹)	37.5/3,000 (28.0/3,000)
					Lubricating oil capacity	gal. (L)	1.6 (6)
					Coolant capacity (including radiator)	gal. (L)	1.7 (6.5)
			Battery		80D26R (12V) equivalent		

Outline drawing

Unit:in.(mm)

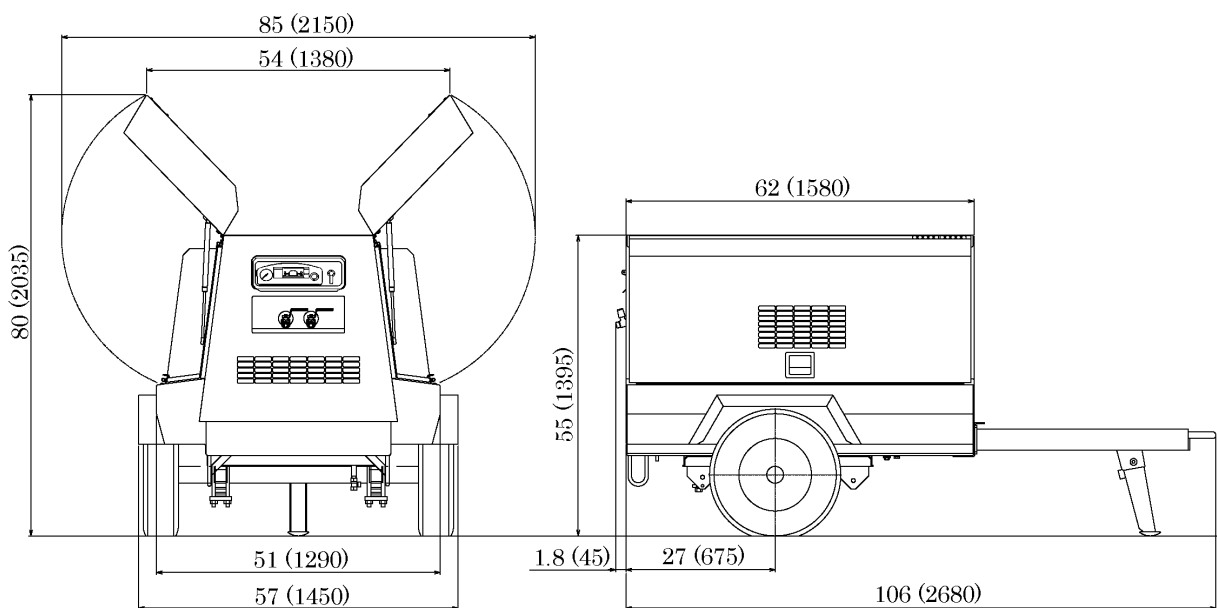

A040290

8. Specifications

PDS185S-6B4

〈 〉 shows 49HP specifications

General Specifications	Overall length	in. (mm)	127 (3,226)	Compressor	Type		Single-stage oil cooled, screw type compressor
	Overall length (bonnet only)	in. (mm)	73 (1,850)		Free air delivery	cfm (m ³ /min)	177 〈 166 〉 (5.0) 〈 (4.7) 〉
	Overall width	in. (mm)	57 (1,450)		Working pressure	psi (bar)	100 (6.9)
	Overall height	in. (mm)	55 (1,395)		Lubricating system		Forced lubrication by compressed pressure
	Net dry mass	lb (kg)	2,249 (1,020)		Driving system		Direct driving with gear coupling
	Operating mass	lb (kg)	2,480 (1,125)		Receiver tank capacity	cu in. (m ³)	1,833 (0.030)
	Fuel tank capacity	gal. (L)	24 (90)		Lubricating oil capacity	gal. (L)	4.2 (16)
				Engine	Model		NISSAN TD27
					Type		Water-cooled 4-cycle swirl chamber type
					Number of cylinders, bore stroke	in. (mm)	4-3.78in. × 3.62in. 4-96mm × 92mm
					Total displacement	cu in. (L)	162.5 (2.663)
					Rated output	hp/rpm (kW/min ⁻¹)	51.6/2,600 〈45.7/2,400〉 (38.0/2,600) 〈(34.1/2,400)〉
					Lubricating oil capacity	gal. (L)	3.2 (12)
					Coolant capacity (including radiator)	gal. (L)	2.3 (8.5)
			Battery		80D26R (12V) equivalent		

Outline drawing

Unit:in.(mm)

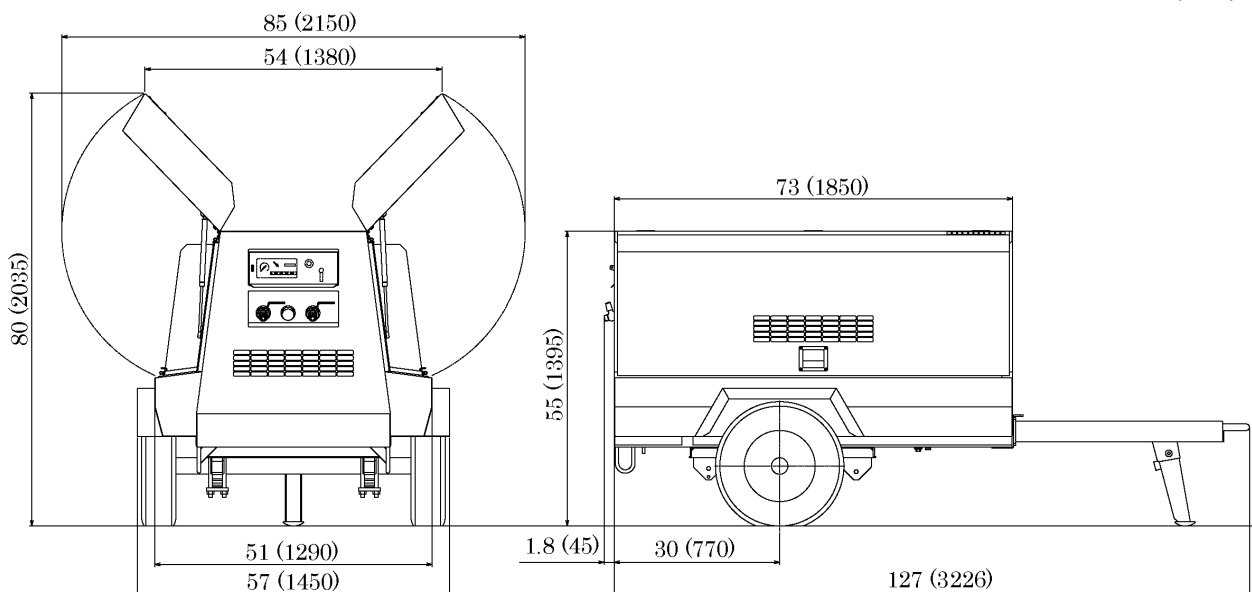

A000085

9. Wiring Diagram

PDS100S-6B4
PDS130S-6B4

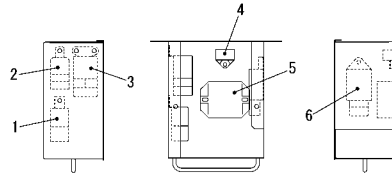

Mounting position of the bracket on switch panel

No.	Part No.	Part name	Type
1	44346 06300	Solenoid relay	SHIBAURA185206300
2	44346 12700	Safety relay	SHIBAURA185206220
3	44346 14800	Glow relay	SHIBAURA185206410
4	46948 00700	Varistor	SHIBAURA185596050
5	44323 06600	Alternator regulator	SHIBAURA185516170
6	44346 12500	Glow controller	SHIBAURA385870960

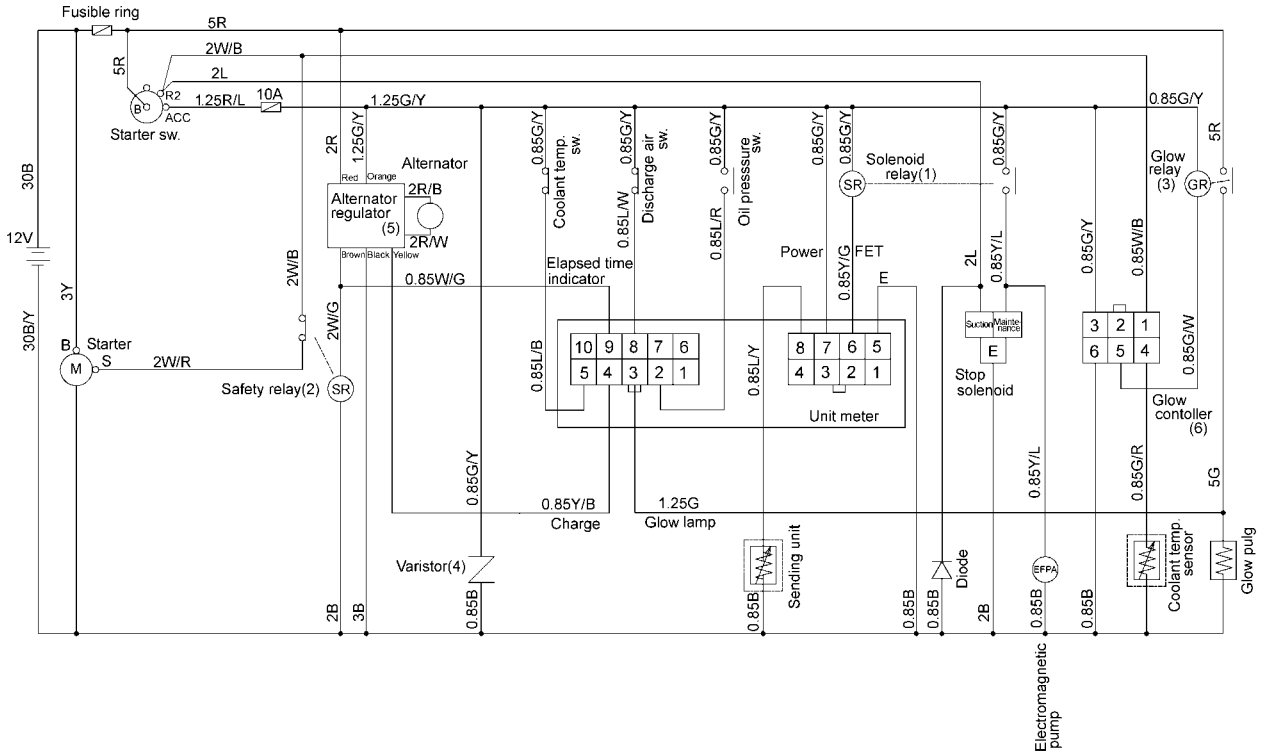

A050044E

9. Wiring Diagram

PDS185S-6B4

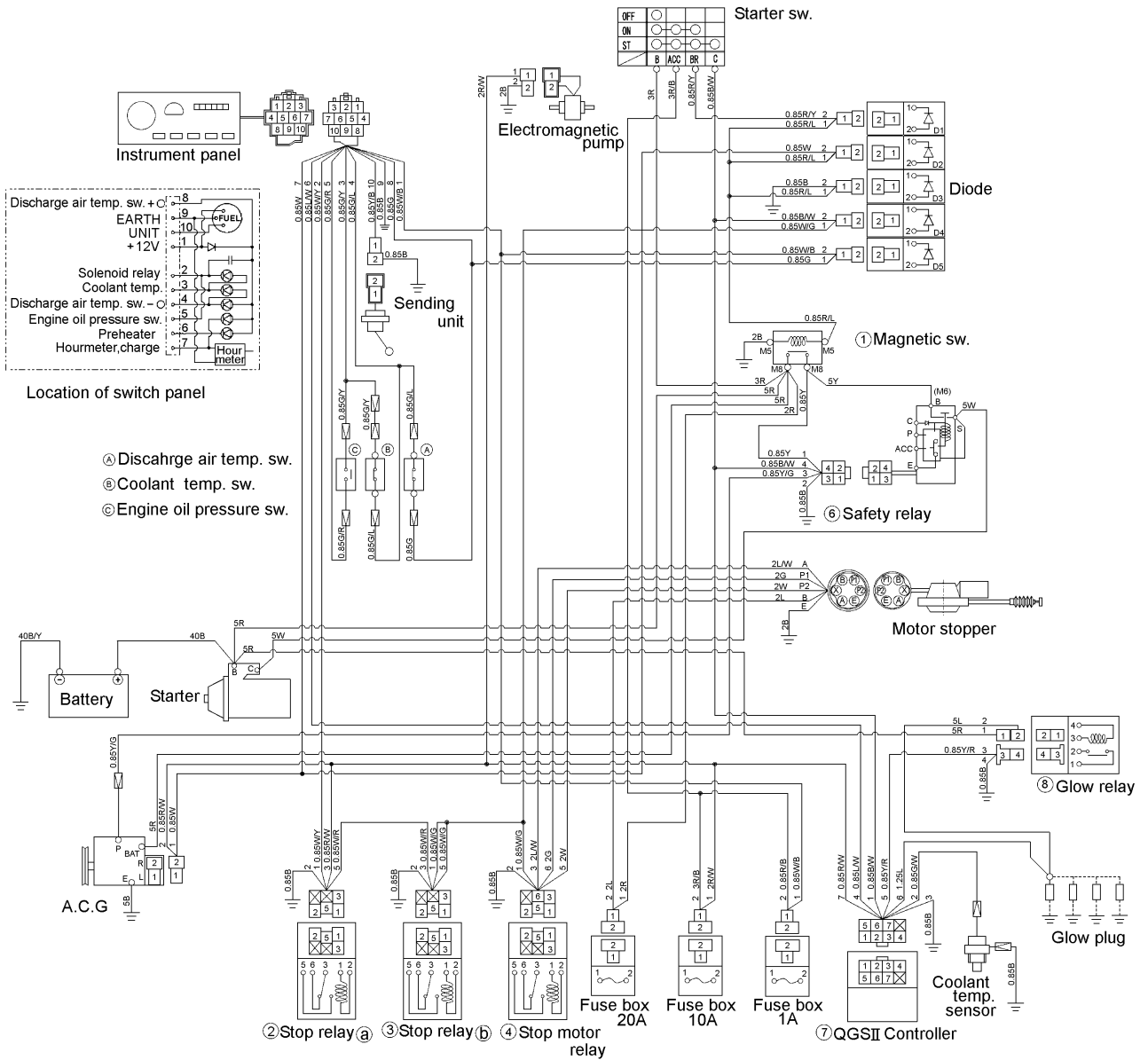

A090157

10. Piping Diagram

PDS100S-6B4

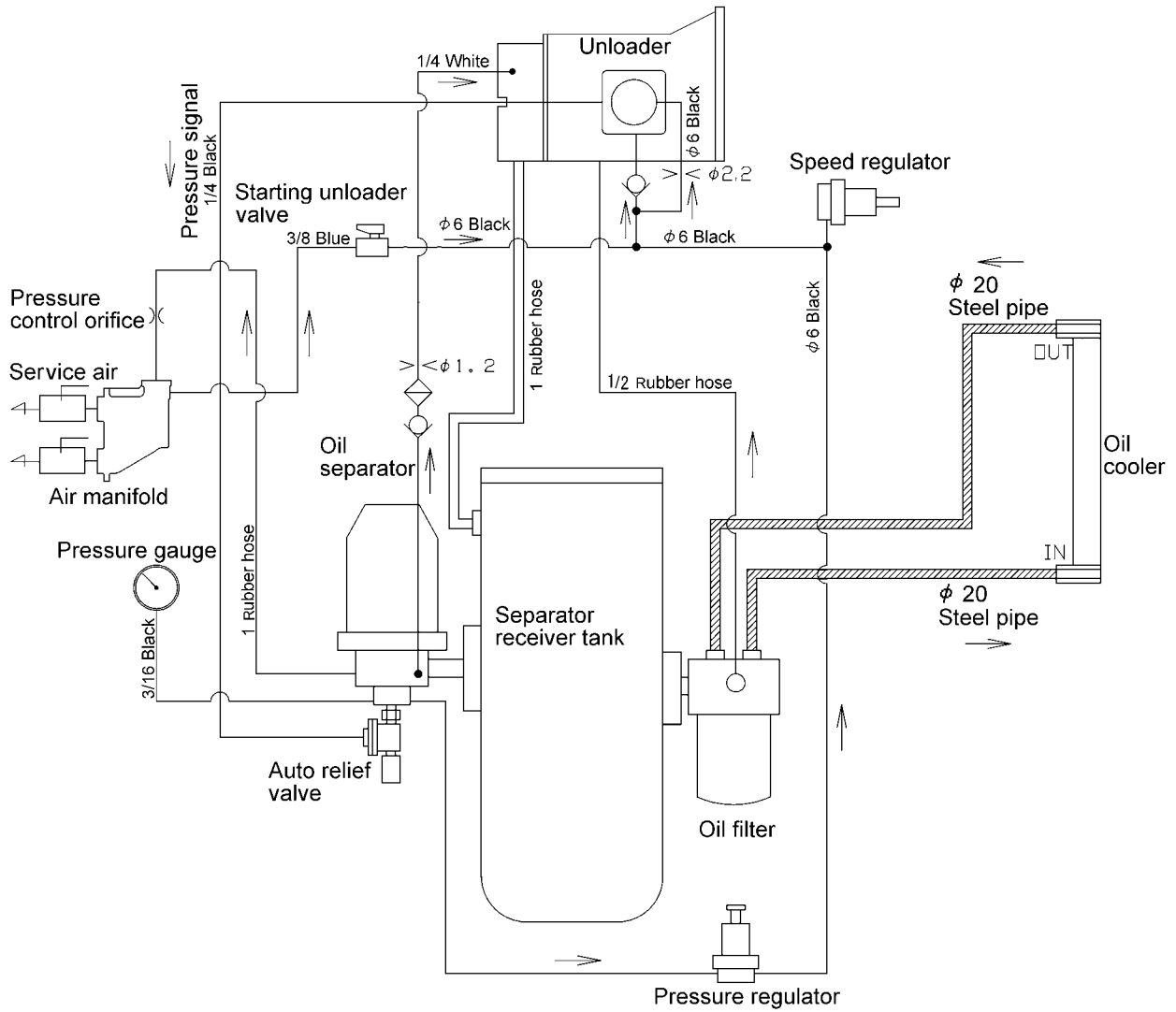

A050211

10. Piping Diagram

PDS130S-6B4

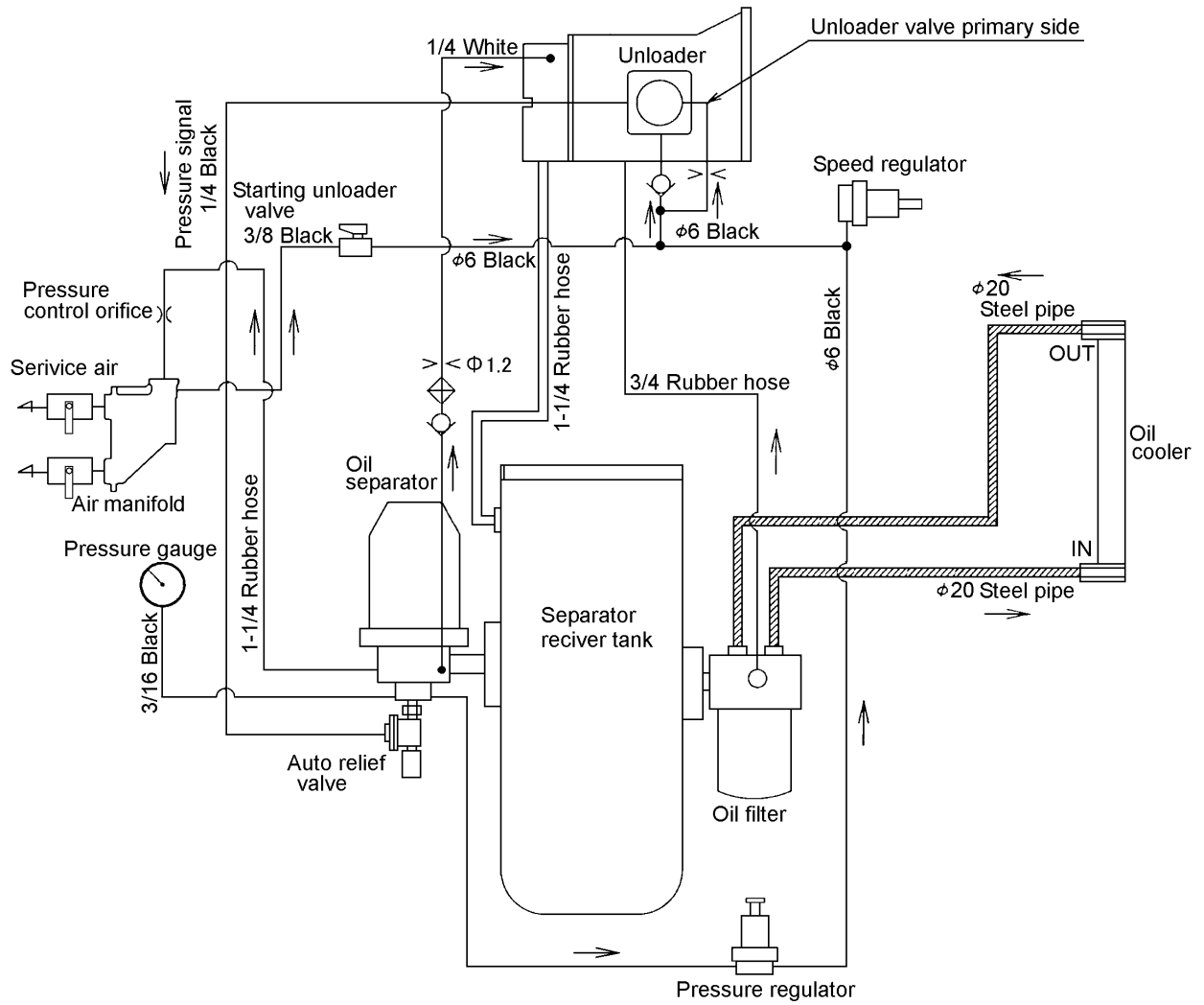

A050222E-1

10. Piping Diagram

PDS185S-6B4

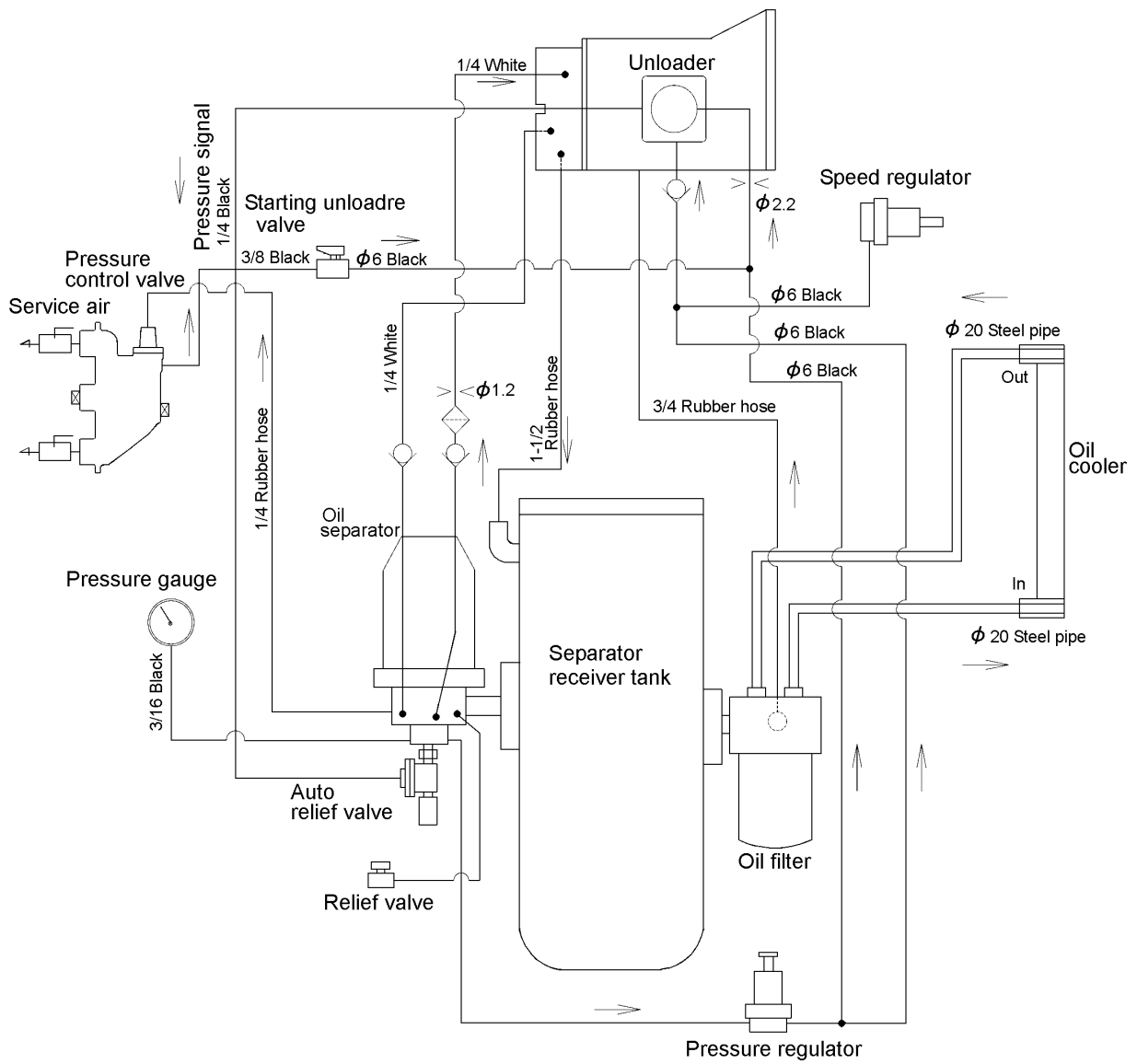

A050228

HOKUETSU INDUSTRIES CO., LTD.

8TH FLOOR SHINJUKU SAN-EI BLDG,
22-2 NISHI-SHINJUKU 1-CHOME, SHINJUKU-KU
TOKYO 160-0023 JAPAN
TEL:81-3-3348-7281
FAX:81-3-3348-7289
URL:<http://www.airman.co.jp>

Copyright(C)2009 HOKUETSU INDUSTRIES CO., LTD. All Rights Reserved

39600 99720
PRINTED IN JAPAN 2009.11

AIRMAN

HOKUETSU INDUSTRIES CO., LTD.